



# Contents

Built-in Ovens **4-33**

Hobs **36-55**

Range Hoods **58-71**



# Built-in Ovens





# A6 & B66 SERIES

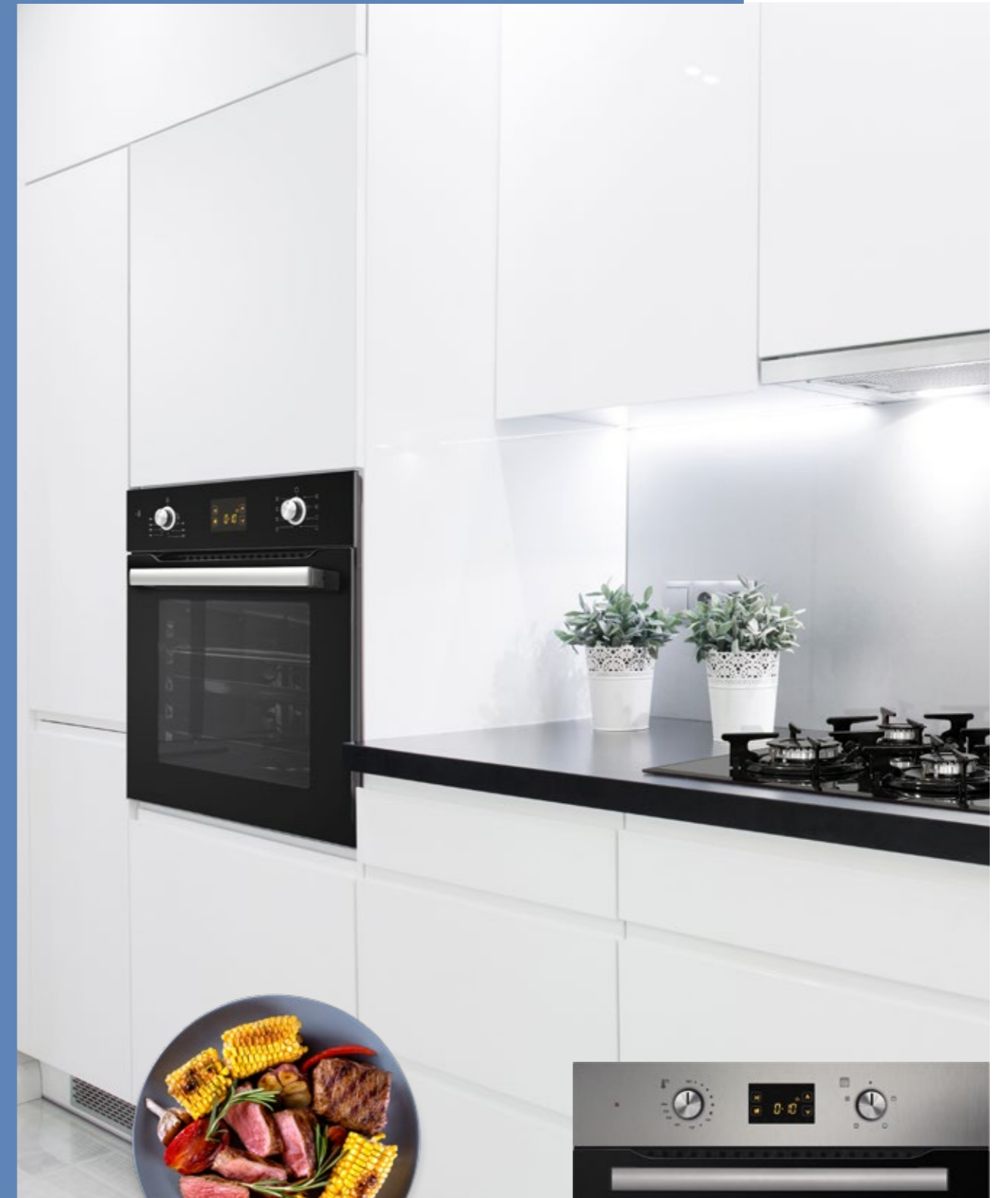

If you are fond of traditional cooking, you need a traditional cook. The oven cooks food using conventional heating elements and fans. Equipped models and fans help distribute hot air more evenly throughout the oven cavity, allowing for more cooking sensitivity. There are two models to choose from: the A6 series and the B66 series.



# HARR TECHNOLOGY



## %40 Energy Saving

Our built-in products with Harr technology can be produced in A and A+ energy classes and provide maximum cooking performance with minimum energy consumption. Compared to the built-in ovens of competitor companies in the same energy class, performed under laboratory conditions, our products provide energy savings of up to 40%.





## Telescopic Rail

We have 2 different rail systems, extendable and fully extendable, and thanks to the telescopic rail system the tray can be easily shelved in the oven. Telescopic rails facilitate cooking control during cooking.



## Easy To Clean Panel

Thanks to the High technology smooth glasses, in our Built-in Ovens, the entire surface of the oven can be easily cleaned. Thanks to the pop-up buttons and the touchscreen digital screen. Interior lighting, you are always in control of the food cooked in the oven.



## Easy Removable Inner Glass for Cleaning

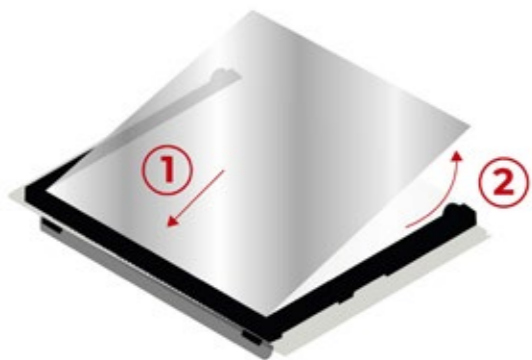

The inner glass of our built-in ovens can be removed and cleaned manually. The dirt, that is stuck between 2 glasses, can be reached easily.



## Catalytic Cavity

The special removable catalytic material is covering the inner surface of our built-in ovens, absorbs oil residues that cause visual pollution and bad smells. Catalytic walls, which regularly absorb the splashing oils during cooking, increase comfort by saving the customer from cleaning.





## Wire Shelf System

Side wire shelves in our built-in ovens can be easily removed and it's suitable for washing with dishwasher thereby it will be ready for next use effortless.



## Pyrolytic Cleaning System

The temperature inside the oven rises to 450°C - 480°C thereby grease and food residues on the oven's inner walls, burnt. Burnt wastes are cleaned through the catalyst chimney and given to the kitchen environment purely. All you have to do is clean the inside of the oven with a damp cloth.

Pyrolytic cleaning time: 90 minutes.

## Defrost

In de-frost mode, no heating mood is used. Only the fan is activated to circulate the air inside the oven. You can gently defrost frozen food at room temperature or cool cooked food.





## Cool Touch Door

Thanks to the 3 glasses that is applied in our Built-in Ovens, the inside of the oven is keeping warm, while the heating. The outer glass is prevented from the heat by indoor glasses.



## Rotisserie

Our built-in ovens have the feature of turning chicken and with this skill, delicious chicken menus can be prepared.



## 3D Cooking Technology

3D Cooking technology activates the lower, upper, and turbo heaters in the oven at the same time and distributes the heat even intensity. In this way, the heat is evenly distributed on all surfaces of the food and ideal cooking takes place. With 3D Cooking technology, food is cooked evenly without burning.







## Anti FingerPrint Panel

The steel coating is stain-proof and has fingerprint-resistant. Even when used on daily touches, the surface remains gleaming and bright.



## Zero Emissions in Gas Ovens

In our gas-formed built-in ovens, the gases that consisted while during the cooking are instantly evacuated by a chimney designed towards the front. Therefore, efficient cooking is provided in the zero-emission environment. As a result of the tests in the laboratory conditions, the carbon monoxide rate in the flue gas was determined as 0%.



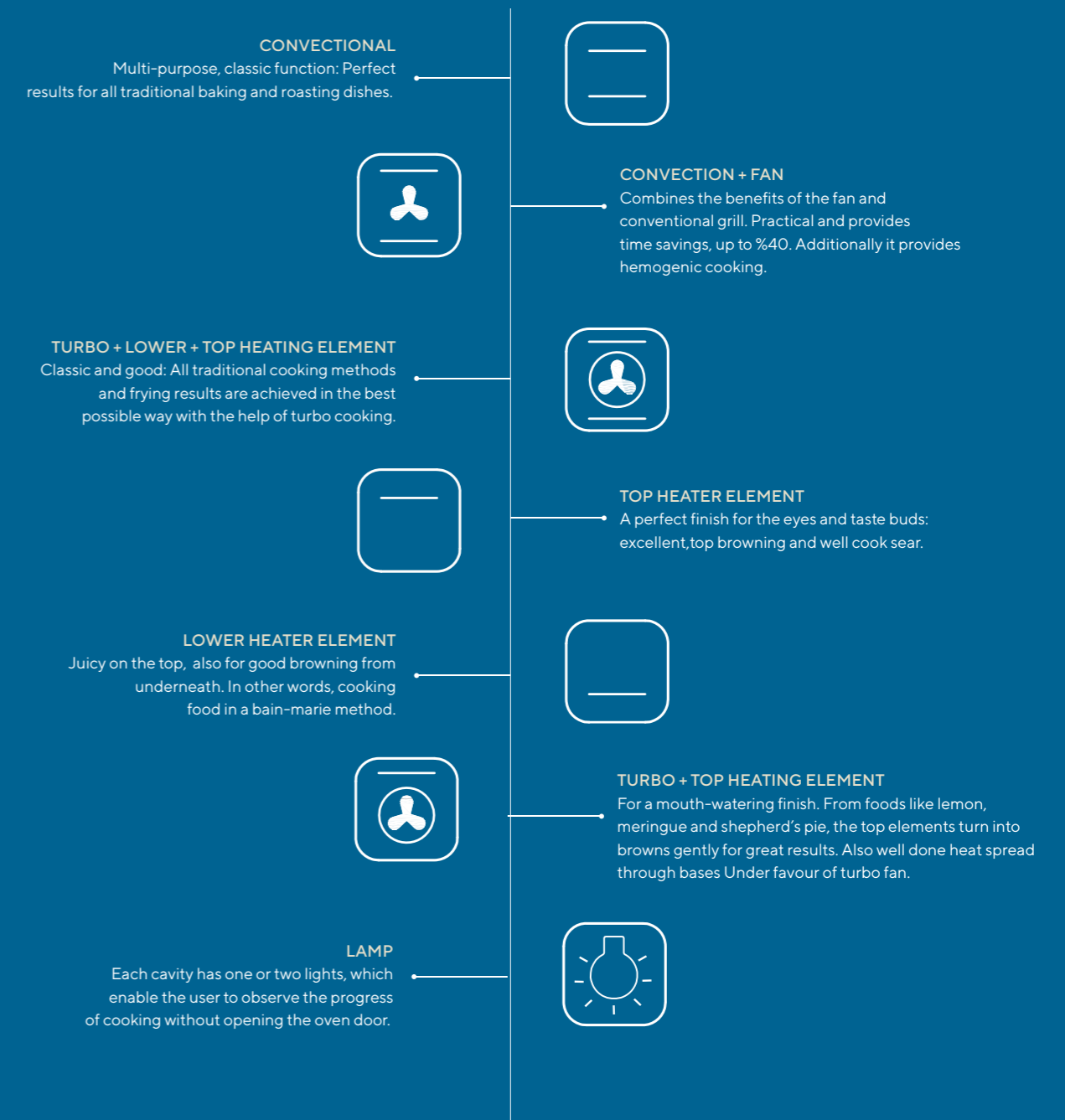
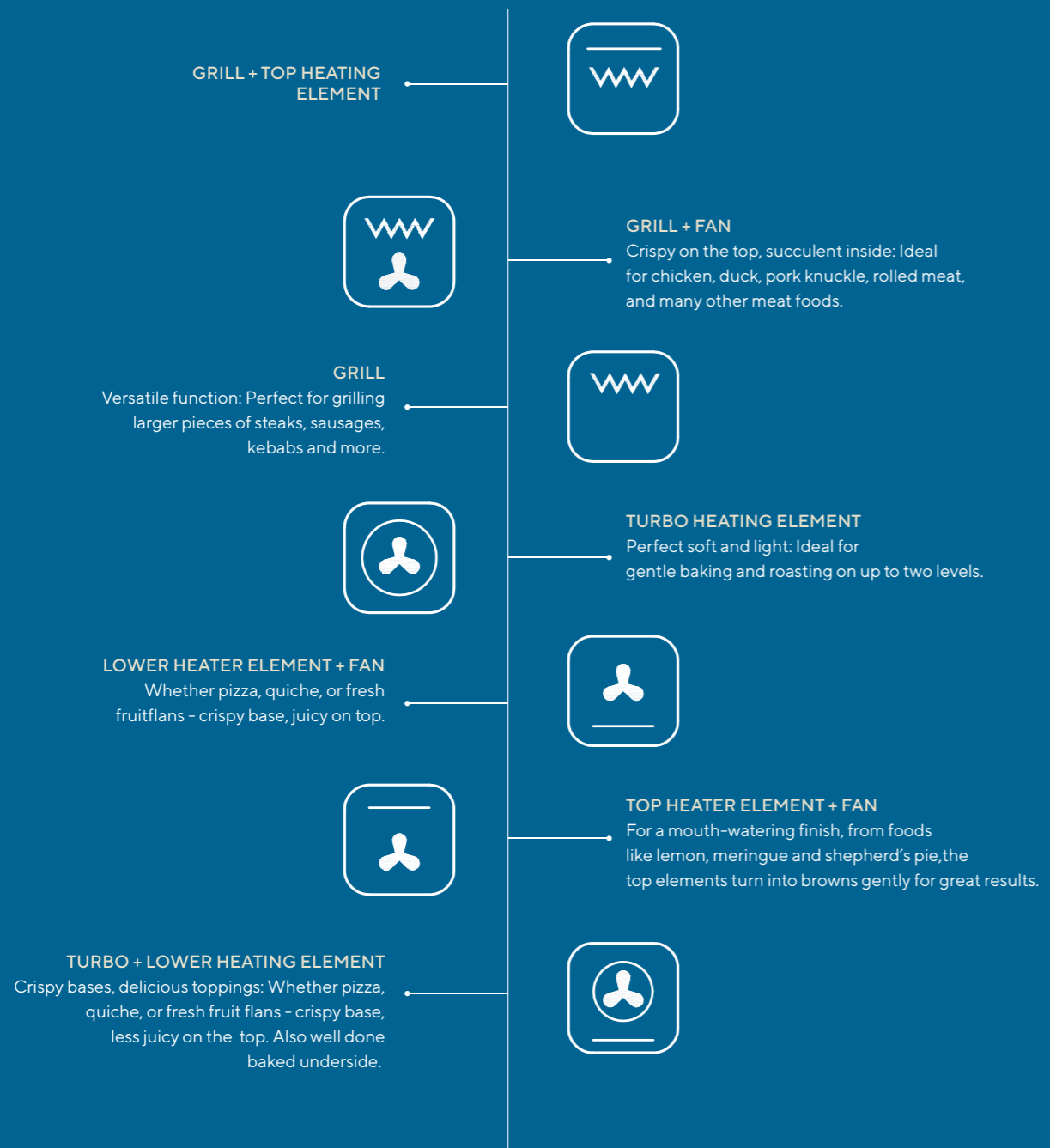



## A6 SERIES FEATURES



### A6-S3

#### Main Features

Easy to clean & removable full glass inner door  
Desired functions can be added  
Enamelled side walls  
Hologen lighting

#### Technical Features

A Energy Class (S2 A+ Energy)  
Oven Capacity: 57-61 L  
H x W x D: 59.5 x 60 x 63.5 cm



### A6-S3 MT

#### Main Features

Mechanic timer  
Easy to clean & removable full glass inner door  
Desired functions can be added  
Hologen lighting  
Enamelled side walls

#### Technical Features

A Energy Class (S2 A+ Energy)  
Oven Capacity: 57-61 L  
H x W x D: 59.5 x 60 x 63.5 cm



### A6-SF3 DT

#### Main Features

6 Buttons digital timer  
Easy to clean & removable full glass inner door  
Desired functions can be added  
Hologen lighting  
Enamelled side walls

#### Technical Features

A Energy Class (SF2 A+ Energy)  
Oven Capacity: 57-61 L  
H x W x D: 59.5 x 60 x 63.5 cm



### A6-SF3 DDT

#### Main Features

Touch control digital timer  
Easy to clean & removable full glass inner door  
Desired functions can be added  
Hologen lighting  
Enamelled side walls

#### Technical Features

A Energy Class (SF2 A+ Energy)  
Oven Capacity: 57-61 L  
H x W x D: 59.5 x 60 x 63.5 cm



## A6 SERIES SPECIFICATION



Model	A6-S3	A6-S3 MT	A6-SF3 DT	A6-SF3 DDT
Capacity (L)	57-61	57-61	57-61	57-61
Voltage (V)	220-240	220-240	220-240	220-240
Frequency (Hz)	50	50	50	50
Product Type	Built-in	Built-in	Built-in	Built-in
Thermostat	Yes	Yes	Yes	Yes
Functions	3	3	4	4
Oven Type	Static	Static	Static + Fan	Static + Fan
Oven Control Panel	Metal or Glass Panel	Metal or Glass Panel	Metal or Glass Panel	Metal or Glass Panel
Display / Timer	-	Mechanical Timer	Led Disp. - 6 Buttons Dig.Tim.	Led Disp.-Touch Cont. Dig.Tim.
Inner Door Type	Full Glass (Removable)	Full Glass (Removable)	Full Glass (Removable)	Full Glass (Removable)
Interior Accessory	1x Cr-ni grid, 1x Enamelled Rectangle Tray	1x Cr-ni grid, 1x Enamelled Rectangle Tray	1x Cr-ni grid, 1x Enamelled Rectangle Tray	1x Cr-ni grid, 1x Enamelled Rectangle Tray
Deep Tray	Optional	Optional	Optional	Optional
Siding	Optional	Optional	Optional	Optional
Soft Close	-	-	-	-
3D Cooking	-	-	Yes	Yes
Defrost Function	-	-	Yes	Yes
Turbo Fan	-	-	Yes	Yes
Grill	Optional	Optional	Optional	Optional
Interior Light	Hologen	Hologen	Hologen	Hologen
Side racks	4	4	4	4
Side Shelves	Enameled or Wire Shelf	Enameled or Wire Shelf	Enameled or Wire Shelf	Enameled or Wire Shelf
Telescopic Rail	Optional	Optional	Optional	Optional
Cooling Fan	Yes	Yes	Yes	Yes
Fan Heating	-	-	Optional	Optional
Pyrolytic Cleaning System	-	-	-	-
Harr Technology (S2 or SF2)	Optional	Optional	Optional	Optional
Total Power	2300 W (Harr Technology 2000 W)	2300 W (Harr Technology 2000 W)	2300 W (Harr Technology 2000 W)	2300 W (Harr Technology 2000 W)

Metal panel color options: Black, White, Beige, Stainless steel  
Glass panel color options: Black, White, Stone Coal



# A6 SERIES FEATURES



## A6-M3 DDT

### Main Features

Touch control digital timer  
 Easy to clean & removable full glass inner door  
 Desired functions can be added  
 Hologen lighting  
 Enamelled side walls

### Technical Features

A Energy Class (M2 A+ Energy)  
 Oven Capacity: 57-61 L  
 H x W x D: 59.5 x 60 x 63.5 cm

Model	A6-M3 DDT
Capacity (L)	57-61
Voltage (V)	220-240
Frequency (Hz)	50
Product Type	Built-in
Thermostat	Yes
Functions	7
Oven Type	Multi
Oven Control Panel	Metal or Glass Panel
Display / Timer	-
Inner Door Type	Full Glass (Removable)
Interior Accessory	1 x Cr-ni grid, 1 x Enamelled Rectangle Tray
Deep Tray	Optional
Siding	Optional
Soft Close	-
3D Cooking	Yes
Defrost Function	Yes
Turbo Fan	Yes
Grill	Yes
Interior Light	Hologen
Side racks	4
Side Shelves	Embedded or Wire Shelf
Telescopic Rail	Optional
Cooling Fan	Yes
Fan Heating	Yes
Pyrolytic Cleaning System	-
Harr Technology (M2)	Optional
Total Power	4100 W (Harr Technology 3800 W)

Metal panel color options: Black, White, Beige, Stainless steel  
 Glass panel color options: Black, White, Stone Coal





## A6 SERIES GAS FEATURES



### A6-GG

#### Main Features

Oven type: Gas cooking  
Easy to clean & removable full glass inner door  
Enamelled side walls  
Hologen lighting

#### Technical Features

Oven Capacity: 54-61 L  
H x W x D: 59.5 x 60 x 63.5 cm



### A6-GG MT

#### Main Features

Oven type: Gas cooking  
Mechanic timer  
Easy to clean & removable full glass inner door  
Hologen lighting  
Enamelled side walls

#### Technical Features

Oven Capacity: 54-61 L  
H x W x D: 59.5 x 60 x 63.5 cm



### A6-GGF DT

#### Main Features

6 Buttons digital timer  
Easy to clean & removable full glass inner door  
Hologen lighting  
Enamelled side walls

#### Technical Features

Oven Capacity: 54-61 L  
H x W x D: 59.5 x 60 x 63.5 cm



### A6-GGF DDT

#### Main Features

Touch control digital timer  
Easy to clean & removable full glass inner door  
Hologen lighting  
Enamelled side walls

#### Technical Features

Oven Capacity: 54-61 L  
H x W x D: 59.5 x 60 x 63.5 cm



## A6 SERIES GAS SPECIFICATION



Model	A6-GG	A6-GG MT	A6-GGF DT	A6-GGF DDT
Capacity (L)	54-61	54-61	54-61	54-61
Voltage (V)	220-240	220-240	220-240	220-240
Frequency (Hz)	50	50	50	50
Product Type	Built-in	Built-in	Built-in	Built-in
Thermostat	Optional	Optional	Optional	Optional
Oven Type	Gas+Gas	Gas+Gas	Gas+Gas+Fan	Gas+Gas+Fan
Oven Control Panel	Metal + Glass Panel	Metal + Glass Panel	Metal + Glass Panel	Metal + Glass Panel
Led Disp.- Touch Cont.Dig.Tim.	-	Mechanical Timer	Led Display - 6 But. Dig.Tim.	Led Display - Touch Pad
Inner Door Type	Full Glass (Removable)	Full Glass (Removable)	Full Glass (Removable)	Full Glass (Removable)
Deep Tray	Optional	Optional	Optional	Optional
Interior Accessory	1 x Cr-ni grid, 1 x Enamelled Rectangle Tray	1 x Cr-ni grid, 1 x Enamelled Rectangle Tray	1 x Cr-ni grid, 1 x Enamelled Rectangle Tray	1 x Cr-ni grid, 1 x Enamelled Rectangle Tray
Siding	I Siding	I Siding	I Siding	I Siding
Soft Close	-	-	-	-
3D Cooking	-	-	-	-
Turbo Fan	-	-	Yes	Yes
Interior Light	Hologen	Hologen	Hologen	Hologen
Shelf Positions	4	4	4	4
Side Shelves	Wire Shelf or Embedded	Wire Shelf or Embedded	Wire Shelf or Embedded	Wire Shelf or Embedded
Telescopic Rail	Optional	Optional	Optional	Optional
Cooling Fan	Yes	Yes	Yes	Yes
Pyrolytic Cleaning System	-	-	-	-
Ignition	Auto or Button	Auto or Button	Auto or Button	Auto or Button
Flame Failure Device (FFD)	Yes	Yes	Yes	Yes

Metal panel color options: Black, White, Beige, Stainless steel  
Glass panel color options: Black, White, Stone Coal





## B66 SERIES FEATURES



### B66-S3

#### Main Features

3 Functions  
Easy to clean & removable full glass inner door  
Enamelled side walls  
Hologen lighting

#### Technical Features

A Energy Class (S2 A+ Energy)  
Oven Capacity: 50-56 L  
H x W x D: 59.5 x 59 x 54.5 cm



### B66-S3 MT

#### Main Features

Mechanic timer  
3 Functions  
Easy to clean & removable full glass inner door  
Hologen lighting  
Enamelled side walls

#### Technical Features

A Energy Class (S2 A+ Energy)  
Oven Capacity: 50-56 L  
H x W x D: 59.5 x 59 x 54.5 cm



### B66-SF3 DT

#### Main Features

6 Buttons digital timer  
4 Functions  
Easy to clean & removable full glass inner door  
Hologen lighting  
Enamelled side walls

#### Technical Features

A Energy Class (SF2 A+ Energy)  
Oven Capacity: 50-56 L  
H x W x D: 59.5 x 59 x 59 cm



### B66-SF3 DDT

#### Main Features

Touch control digital timer  
4 Functions  
Easy to clean & removable full glass inner door  
Hologen lighting  
Enamelled side walls

#### Technical Features

A Energy Class (SF2 A+ Energy)  
Oven Capacity: 50-56 L  
H x W x D: 59.5 x 59 x 59 cm



## B66 SERIES SPECIFICATION



Model	B66-S3	B66-S3 MT	B66-SF3 DT	B66-SF3 DDT
Capacity (L)	50-56	50-56	50-56	50-56
Voltage (V)	220-240	220-240	220-240	220-240
Frequency (Hz)	50	50	50	50
Product Type	Built-in	Built-in	Built-in	Built-in
Thermostat	Yes	Yes	Yes	Yes
Functions	3	3	4	4
Oven Type	Static	Static	Static + Fan	Static + Fan
Oven Control Panel	Metal or Glass Panel	Metal or Glass Panel	Metal or Glass Panel	Metal or Glass Panel
Display / Timer	-	Mechanical Timer	Led Disp. - 6 Buttons Dig.Tim.	Led Disp.-Touch Cont. Dig.Tim.
Inner Door Type	Full Glass (Removable)	Full Glass (Removable)	Full Glass (Removable)	Full Glass (Removable)
Interior Accessory	1x Cr-ni grid, 1x Enamelled Rectangle Tray	1x Cr-ni grid, 1x Enamelled Rectangle Tray	1x Cr-ni grid, 1x Enamelled Rectangle Tray	1x Cr-ni grid, 1x Enamelled Rectangle Tray
Deep Tray	Optional	Optional	Optional	Optional
Siding	Optional	Optional	Optional	Optional
Soft Close	-	-	-	-
3D Cooking	-	-	-	-
Defrost Function	-	-	Yes	Yes
Turbo Fan	-	-	Yes	Yes
Grill	Optional	Optional	Optional	Optional
Interior Light	Hologen	Hologen	Hologen	Hologen
Shelf Positions	4	4	4	4
Side Shelves	Embedded or Wire Shelf	Embedded or Wire Shelf	Embedded or Wire Shelf	Embedded or Wire Shelf
Telescopic Rail	Optional	Optional	Optional	Optional
Cooling Fan	Yes	Yes	Yes	Yes
Fan Heating	-	-	-	-
Sabbath Function	Optional	Optional	-	-
Pyrolytic Cleaning System	Optional	Optional	Optional	Optional
Harr Technology (S2 or SF2)	Optional	Optional	Optional	Optional
Total Power	1900 W (Harr Technology 1600 W)	1900 W (Harr Technology 1600 W)	1900 W (Harr Technology 1600 W)	1900 W (Harr Technology 1600 W)

Metal panel color options: Black, White, Beige, Stainless steel  
Glass panel color options: Black, White, Stone Coal



## B66 SERIES FEATURES



### B66-M3 DDT

#### Main Features

Touch control digital timer  
7 Functions  
Easy to clean & removable full glass inner door  
Hologen lighting  
Enamelled side walls

#### Technical Features

A Energy Class (M2 A+ Energy)  
Oven Capacity: 50-56 L  
H x W x D: 59.5 x 59 x 59 cm

Model	B66 M3 DDT
Capacity (L)	50-56
Voltage (V)	220-240
Frequency (Hz)	50
Product Type	Built-in
Thermostat	Yes
Functions	7
Oven Type	Multi
Oven Control Panel	Metal or Glass Panel
Display / Timer	Led Disp.-Touch Cont. Dig.Tim.
Inner Door Type	Full Glass (Removable)
Interior Accessory	1x Cr-ni grid, 1x Enamelled Rectangle Tray
Deep Tray	Optional
Siding	Optional
Soft Close	-
3D Cooking	Yes
Defrost Function	Yes
Turbo Fan	Yes
Grill	Grill
Interior Light	Hologen
Shelf Positions	4
Side Shelves	Embedded or Wire Shelf
Telescopic Rail	Optional
Cooling Fan	Yes
Fan Heating	Yes
Sabbath Function	-
Pyrolytic Cleaning System	Optional
Harr Technology (M2)	Optional
Total Power	3700 W (Harr Technology 3400 W)



## B66 SERIES FEATURES



### B66-S3 AT

#### Main Features

- Analog timer (Optional Mechanic Timer)
- Metal or Glass panel
- 3 Functions
- Easy to clean & removable full glass inner door
- Hologen lighting
- Enamelled side walls

#### Technical Features

- A Energy Class (S2 A+ Energy)
- Oven Capacity: 50-56 L
- H x W x D: 59.5 x 59 x 54.5 cm



**RUSTIC DESIGN**  
COMES WITH BEIGE & BLACK OPTIONS







# SIDING OPTIONS



Kumtel proudly presents its new built-in oven series that will make a difference in your kitchen with its elegance and design.

**Rustic Siding**

**U Siding**

**I Siding**

**O Siding**





# Hobs



# BUILT-IN & COOKTOP SERIES



## Step by step (10 position flame adjust)

Our new Kumtel Gas hobs with a step-flame feature enable you to select and control the power level and ensures you get perfectly repeatable results every time you cook. Elegant knobs with 10 power level indicators, once you get the perfect taste you can always catch the same flavor, just follow the same heat and flame. Plus, the illuminated buttons let you know what's going on, even from distances. With all the control at your fingertips, let's turn your cuisine time into art.

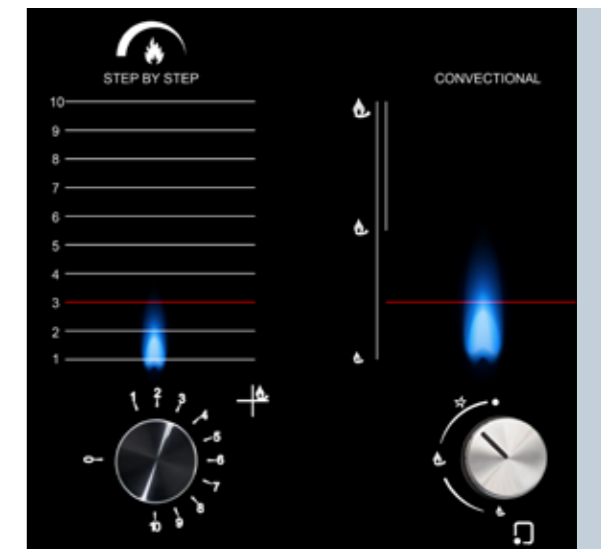



## Gas Safety System

If the wind blows your gas fire out or your pan boils too much and spilled, while you're under the spell of a gripping storyline, the gas safety feature will automatically turn your gas supply off, keeping you and your place safe. Even you aren't there.

## Cast Iron Pan Support

Favorite-pot-fans don't want their precious dinner spill, because of the pot rocking or tilting on the hob. That's where Cast Iron Pan Supports can help. They offer maximum stability to all shapes and sizes of pans. Plus, they add some professional style to your hob.

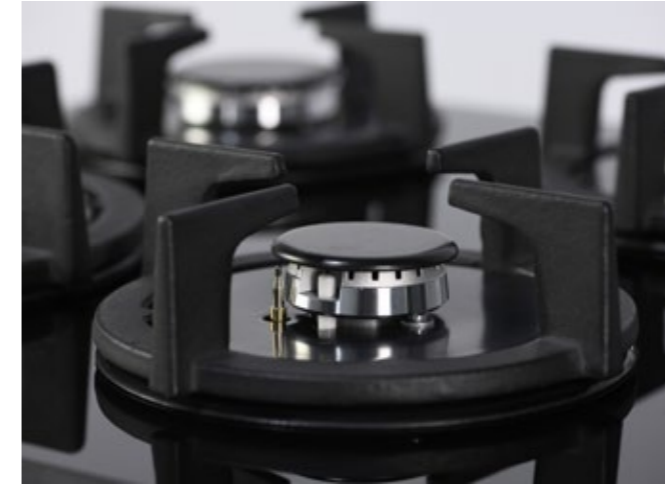

## Dishwasher Safe Grids

The round pan supports that we used in our hob and free-standing ovens can be cleaned easily with their dishwasher-safe feature





## Automatic Ignition

Total control of the ignition, convenient through a single-handed operation of turning the knob to automatically ignite the hob.

## Hob

Here comes Kumtel glass surface cooker, easy to clean, scratch-resistant, gorgeous, and beautifully reflective.



## Tribble Burner

The Kumtel High Power Tribble Burner provides you an extremely intense flame with two separate flame rings. Tribble burner allows heat to distribute more evenly to the bottom of the pan and provides cooking efficiency and time advantage.





# ELECTRIC BUILT-IN FEATURES

## V3-02P

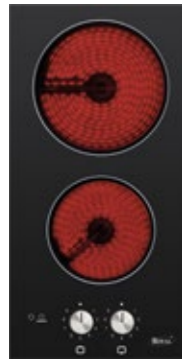

### Main Features

Front Knob Control  
9 Cooking Levels Per Zone  
Front: 140 mm / 1200 W  
Rear: 180 mm / 1800 W  
On-off indicator light

### Technical Features

Total Power: 3000 W  
Product Dimensions: 29 x 52 cm

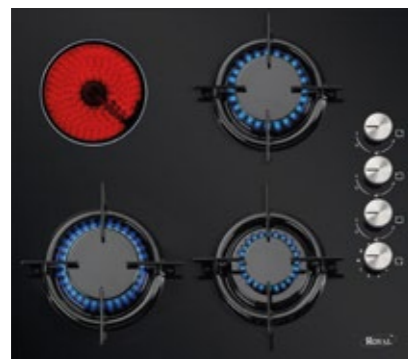

## V6-31 PYF

### Main Features

Side Knob Control  
Gas Safety  
Auto Ignition  
Left Rear: 140 mm / 1200 W  
Right Rear: 1,65 KW  
Left Front: 2,20 KW  
Right Front: 1,10 KW

### Technical Features

Total Power: 1200 W  
Product Dimensions: 52 x 59 cm

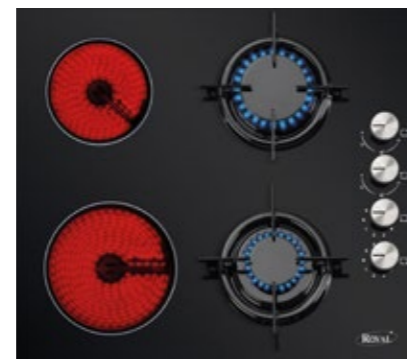

## V6-22 PYF

### Main Features

Side Knob Control  
Gas Safety  
Auto Ignition  
Left Rear: 140 mm / 1200 W  
Right Rear: 1,65 KW  
Left Front: 180 mm / 1800 W  
Right Front: 1,10 KW

### Technical Features

Total Power: 3000 W  
Product Dimensions: 52 x 59 cm

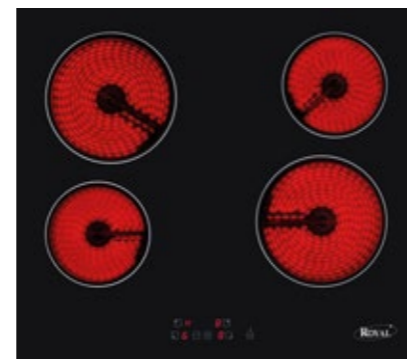

## V6-04T

### Main Features

Touch Digital Control  
Left Front: 140 mm / 1200 W  
Right Front: 180 mm / 1800 W  
Left Rear: 180 mm / 1800 W  
Right Rear: 140 mm / 1200 W

### Technical Features

Total Power: 6000 W  
Product Dimensions: 52 x 59 cm

# ELECTRIC BUILT-IN SPECIFICATION

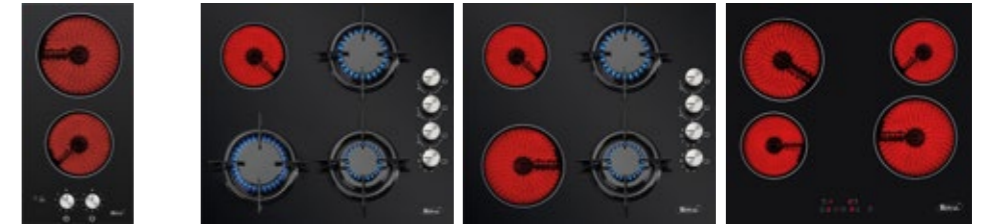

Model	V3-02 P	V6-31 PYF	V6-22 PYF	V6-04 T
Product Type	Built-in	Built-in	Built-in	Built-in
Location of Control Panel	Front	Side	Side	Front
Hobs Width (Cm)	30	60	60	60
Flame Failure Device (FFD)	-	Yes	Yes	-
Voltage	220-240	220-240	220-240	380
Frequency (Hz)	50-60	50-60	50-60	50-60
Ignition	-	Yes	Yes	-
Pan Support Type	-	Cast Iron - Enamelled	Cast Iron - Enamelled	-
Gas Type	-	LPG or NG	LPG or NG	-
Cooking Level	9	9 (Vitroceramic)	9 (Vitroceramic)	9
Hob Burner Configuration	2 Vitroceramic	1 Vitroceramic + 3 Gas	2 Vitroceramic + 2 Gas	4 Vitroceramic
Depth (Mm)	520	520	520	520
Width (Mm)	290	590	590	590
Height (Mm)	90	105	105	90
Weight (Kg)	4,5	9	9	8





# GAS BUILT-IN FEATURES

## C3-10 BTF



### Main Features

- Tempered Glass Surface
- Tribble Burner
- Gas Safety System
- Auto Ignition

### Technical Features

- Tribble Burner: 1 x 3,60 KW
- Product Dimensions: 29 x 52 cm

## C3-20 BF



### Main Features

- Tempered Glass Surface
- Gas Safety System
- Auto Ignition

### Technical Features

- Rapid Burner: 1 x 2,20 KW
- Auxiliary Burner: 1 x 1,10 KW
- Product Dimensions: 29 x 52 cm



## C6-40 BF (SIDE CONTROL)

### Main Features

- Tempered Glass Surface
- Gas Safety System
- Auto Ignition

### Technical Features

- Rapid Burner: 1 x 2,20 KW
- Semi Rapid Burner: 2 x 1,65 KW
- Auxiliary Burner: 1 x 1,10 KW
- Product Dimensions: 52 x 60 cm



## C6-40 BTF (SIDE CONTROL)

### Main Features

- Tempered Glass Surface
- Tribble Burner
- Gas Safety System
- Auto Ignition

### Technical Features

- Tribble Burner: 1 x 3,60 KW
- Rapid Burner: 1 x 2,20 KW
- Semi Rapid Burner: 2 x 1,65 KW
- Auxiliary Burner: 1 x 1,10 KW
- Product Dimensions: 52 x 60 cm



## C6-40 BTF Platinum (SIDE CONTROL)

### Main Features

- Tempered Glass Surface
- Tribble Burner
- Cast Iron Pan Support
- Step By Step 10 Leves Gas Adjustment
- Gas Safety System
- Auto Ignition

### Technical Features

- Tribble Burner: 1 x 3,60 KW
- Rapid Burner: 1 x 2,20 KW
- Semi Rapid Burner: 2 x 1,65 KW
- \*Auxiliary Burner: 1 x 1,10 KW
- \*Product Dimensions: 52 x 60 cm



## C6-40 BF (FRONT CONTROL)

### Main Features

- Tempered Glass Surface
- Gas Safety System
- Auto Ignition

### Technical Features

- Rapid Burner: 1 x 2,20 KW
- Semi Rapid Burner: 2 x 1,65 KW
- Auxiliary Burner: 1 x 1,10 KW
- Product Dimensions: 60 x 52 cm



## C7-50 BTF

### Main Features

- Tempered Glass Surface
- Tribble Burner
- Gas Safety System
- Auto Ignition

### Technical Features

- Tribble Burner: 1 x 3,60 KW
- Rapid Burner: 1 x 2,20 KW
- Semi Rapid Burner: 2 x 1,65 KW
- Auxiliary Burner: 1 x 1,10 KW
- Product Dimensions: 52 x 75 cm



## C9-50 BTF (FRONT CONTROL)

### Main Features

- Tempered Glass Surface
- Tribble Burner
- Gas Safety System
- Auto Ignition

### Technical Features

- Tribble Burner: 1 x 3,60 KW
- Rapid Burner: 1 x 2,20 KW
- Semi Rapid Burner: 2 x 1,65 KW
- Auxiliary Burner: 1 x 1,10 KW
- Product Dimensions: 52 x 90 cm



## C9-50 BTF (SIDE CONTROL)

### Main Features

- Tempered Glass Surface
- Tribble Burner
- Gas Safety System
- Auto Ignition

### Technical Features

- Tribble Burner: 1 x 3,60 KW
- Rapid Burner: 1 x 2,20 KW
- Semi Rapid Burner: 2 x 1,65 KW
- Auxiliary Burner: 1 x 1,10 KW
- Product Dimensions: 52 x 90 cm





### KO-410 BF

**Main Features**

Metal Body  
Gas Safety System  
Auto Ignition

**Technical Features**

Rapid Burner: 1 x 2,20 KW  
Semi Rapid Burner: 2 x 1,65 KW  
Auxiliary Burner: 1 x 1,10 KW  
Product Dimensions: 50 x 58 cm



### KO-412 BF

**Main Features**

Metal Body  
Gas Safety System  
3 Gas + 1 Hotplate  
Auto Ignition

**Technical Features**

Rapid Burner: 1 x 2,20 KW  
Semi Rapid Burner: 1 x 1,65 KW  
Auxiliary Burner: 1 x 1,10 KW  
Electric Hotplate: 1 x 1000 W  
Product Dimensions: 50 x 58 cm



### M6-40 BF Violet

**Main Features**

Metal Body  
Gas Safety System  
Auto Ignition

**Technical Features**

Rapid Burner: 1 x 2,20 KW  
Semi Rapid Burner: 2 x 1,65 KW  
Auxiliary Burner: 1 x 1,10 KW  
Product Dimensions: 52 x 58 cm



### KO-410 BF EKOL

**Main Features**

Front Knob Control  
Metal Body  
Gas Safety System  
Auto Ignition

**Technical Features**

Rapid Burner: 1 x 2,20 KW  
Semi Rapid Burner: 2 x 1,65 KW  
Auxiliary Burner: 1 x 1,10 KW  
Product Dimensions: 52 x 59 cm



### M7-50 BF Flat

**Main Features**

Front Knob Control  
Metal Body  
Tribble Burner  
Gas Safety System  
Auto Ignition

**Technical Features**

Tribble Burner: 1 x 3,60 KW  
Rapid Burner: 1 x 2,20 KW  
Semi Rapid Burner: 2 x 1,65 KW  
Auxiliary Burner: 1 x 1,10 KW  
Product Dimensions: 50 x 68,5 cm



### M6-31 BF Violet

**Main Features**

Metal Body  
3 Gas + 1 Hotplate  
Gas Safety System  
Auto Ignition

**Technical Features**

Rapid Burner: 1 x 2,20 KW  
Semi Rapid Burner: 1 x 1,65 KW  
Auxiliary Burner: 1 x 1,10 KW  
Electric Hotplate: 1 x 1000 W  
Product Dimensions: 52 x 58 cm



### M6-22 BF Violet

**Main Features**

Metal Body  
2 Gas + 2 Hotplate  
Gas Safety System  
Auto Ignition

**Technical Features**

Rapid Burner: 1 x 2,20 KW  
Semi Rapid Burner: 1 x 1,65 KW  
Electric Hotplate:  
1 x 1000 W , 1 x 1500 W  
Product Dimensions: 52 x 58 cm



### M6-04

**Main Features**

Metal Body  
4 Hotplate

**Technical Features**

Electric Hotplate: 2 x 1000 W  
Electric Hotplate: 2 x 1500 W  
Product Dimensions: 50 x 58 cm







### M6-40 BF Nil (Rectangle)

**Main Features**

Front Knob Control  
Metal Body  
Gas Safety System  
Auto Ignition

**Technical Features**

Rapid Burner: 1 x 2,20 KW  
Semi Rapid Burner: 2 x 1,65 KW  
Auxiliary Burner: 1 x 1,10 KW  
Product Dimensions: 52 x 59 cm



### M6-40 BF Nil (Round)

**Main Features**

Front Knob Control  
Metal Body  
Gas Safety System  
Auto Ignition

**Technical Features**

Rapid Burner: 1 x 2,20 KW  
Semi Rapid Burner: 2 x 1,65 KW  
Auxiliary Burner: 1 x 1,10 KW  
Product Dimensions: 52 x 59 cm



### M6-31 BF Nil

**Main Features**

Front Knob Control  
Metal Body  
Gas Safety System  
Auto Ignition

**Technical Features**

Rapid Burner: 1 x 2,20 KW  
Semi Rapid Burner: 1 x 1,65 KW  
Auxiliary Burner: 1 x 1,10 KW  
Electric Hotplate: 1 x 1000 W  
Product Dimensions: 52 x 59 cm



### M6-22 BF Nil

**Main Features**

Front Knob Control  
Metal Body  
Gas Safety System  
Auto Ignition

**Technical Features**

Rapid Burner: 1 x 2,20 KW  
Semi Rapid Burner: 1 x 1,65 KW  
Electric Hotplate: 2 x 1000 W  
Product Dimensions: 52 x 59 cm



### M6-04 Nil

**Main Features**

Front Knob Control  
Metal Body

**Technical Features**

Electric Hotplate: 4 x 1000 W  
Product Dimensions: 52 x 59 cm



# BUILT-IN HOB SPECIFICATION



Model	C3-10 BTF	C3-20 BF	C6-40 BF	C6-40 BF
Product Type	Built-in	Built-in	Built-in	Built-in
Location of Control Panel	Front	Front	Front	Side
Hobs Width (Cm)	30	30	60	60
Flame Failure Device (FFD)	Yes	Yes	Yes	Yes
Voltage (v)	220-240	220-240	220-240	220-240
Frequency (Hz)	50 - 60	50 - 60	50 - 60	50 - 60
Ignition	Auto	Auto	Auto	Auto
Pan Support Type	Cast iron - Enamelled	Cast iron - Enamelled	Cast iron - Enamelled	Cast iron - Enamelled
Gas Type	LPG or NG	LPG or NG	LPG or NG	LPG or NG
Cooking Level	-	-	-	-
Hob Burner Configuration	1 Tribble	2 Gas	4 Gas	4 Gas
Depth (Mm)	520	520	520	520
Width (Mm)	290	290	600	600
Height (Mm)	105	105	105	105
Weight (Kg)	5,5	5,5	10	10



Model	C6-40 BTF	C6-40 BTF	C7-50 BTF	C9-50 BTF	C9-50 BTF
Product Type	Built-in	Built-in	Built-in	Built-in	Built-in
Location of Control Panel	Side	Side	Front	Front	Side
Hobs Width (Cm)	60	60	75	90	90
Flame Failure Device (FFD)	Yes	Yes	Yes	Yes	Yes
Voltage (v)	220-240	220-240	220-240	220-240	220-240
Frequency (Hz)	50-60	50-60	50-60	50-60	50-60
Ignition	Auto	Auto	Auto	Auto	Auto
Pan Support Type	Cast iron - Enamelled	Cast iron - Enamelled	Cast iron - Enamelled	Cast iron - Enamelled	Cast iron - Enamelled
Gas Type	LPG or NG	LPG or NG	LPG or NG	LPG or NG	LPG or NG
Cooking Level	-	10	-	-	-
Hob Burner Configuration	3 Gas 1 Tribble	3 Gas 1 Tribble	4 Gas 1 Tribble	4 Gas 1 Tribble	4 Gas 1 Tribble
Depth (Mm)	520	520	520	520	520
Width (Mm)	590	590	750	900	900
Height (Mm)	105	105	105	105	105
Weight (Kg)	11	12	14	17	17



Model	KO-410 BF	KO-412 BF	M6-40 BF Violet	M6-31 BF Violet	M6-22 BF Violet	M6-04
Product Type	Built-in	Built-in	Built-in	Built-in	Built-in	Built-in
Location of Control Panel	Side	Side	Side	Side	Side	Side
Hobs Width (cm)	60	60	60	60	60	60
Flame Failure Device (FFD)	Yes	Yes	Yes	Yes	Yes	-
Voltage (v)	220-240	220-240	220-240	220-240	220-240	220-240
Frequency (Hz)	50-60	50-60	50-60	50-60	50-60	50-60
Ignition	Auto	Auto	Auto	Auto	Auto	-
Pan Support Type	Cast iron - Enamelled	Cast iron - Enamelled	Cast iron - Enamelled	Cast iron - Enamelled	Cast iron - Enamelled	-
Gas Type	LPG or NG	LPG or NG	LPG or NG	LPG or NG	LPG or NG	-
Cooking Level	-	3 Level for Hotplate	-	3 Level for Hotplate	3 Level for Hotplate	3 Level for Hotplate
Hob Burner Configuration	4 Gas	3 Gas 1 Electric	4 Gas	3 Gas 1 Electric	2 Gas 2 Electric	4 Electric
Depth (Mm)	500	500	520	520	520	500
Width (Mm)	580	580	580	580	580	580
Height (Mm)	100	100	100	100	100	100
Weight (Kg)	6,4	7,5	6,4	7,5	8	8



Model	KO-410 BF Ekol	M6-40 BF Nil	M6-31 BF Nil	M6-22 BF Nil	M6-04 Nil	M7-50 BF Flat
Product Type	Built-in	Built-in	Built-in	Built-in	Built-in	Built-in
Location of Control Panel	Front	Front	Front	Front	Front	Front
Hobs Width (Cm)	60	60	60	60	60	75
Flame Failure Device (FFD)	Yes	Yes	Yes	Yes	-	Yes
Voltage (v)	220-240	220-240	220-240	220-240	220-240	220-240
Frequency (Hz)	50-60	50-60	50-60	50-60	50-60	50-60
Ignition	Auto	Auto	Auto	Auto	-	Auto
Pan Support Type	Cast iron - Enamelled	Cast iron - Enamelled (Rectangle of Round)	Cast iron - Enamelled (Rectangle of Round)	Cast iron - Enamelled (Rectangle of Round)	-	Cast iron - Enamelled
Gas Type	LPG or NG	LPG or NG	LPG or NG	LPG or NG	-	LPG or NG
Cooking Level	-	-	3 Level for Hotplate	3 Level for Hotplates	3 Level for Hotplates	-
Hob Burner Configuration	4 Gas	4 Gas	3 Gas + 1 Electric	2 Gas + 2 Electric	4 Electric	4 Gas + 1 Tribble
Depth (Mm)	520	520	520	520	590	500
Width (Mm)	590	590	590	590	590	685
Height (Mm)	105	100	100	100	100	80
Weight (Kg)	10	10	10	10	10	9,5

# COUNTERTOP HOBS FEATURES



## C3-10 TF

### Main Features

Tempered Glass Surface  
Tribble Burner  
Gas Safety System  
Auto Ignition

### Technical Features

Tribble Burner: 1 x 3,60 KW  
Product Dimensions:  
29 x 52 cm



## C3-20 F

### Main Features

Tempered Glass Surface  
Gas Safety System  
Auto Ignition

### Technical Features

Rapid Burner: 1 x 2,20 KW  
Auxiliary Burner: 1 x 1,10 KW  
Product Dimensions:  
29 x 52 cm



## C6-40 F

### Main Features

Tempered Glass Surface  
Gas Safety System  
Auto Ignition

### Technical Features

Rapid Burner: 1 x 2,20 KW  
Semi Rapid Burner: 2 x 1,65 KW  
Auxiliary Burner: 1 x 1,10 KW  
Product Dimensions:  
52 x 60 cm



## V3-02 P

### Main Features

Front Knob Control  
9 Cooking Levels Per Zone  
Front: 140 mm / 1200 W  
Rear: 180 mm / 1800 W  
On-off indicator light

### Technical Features

Total Power: 3000 W  
Product Dimensions:  
29 x 52 cm



## 204 PUNTO

### Main Features

Metal Body  
4 Gas Burner

### Technical Features

Rapid Burner: 1 x 2,20 KW  
Semi Rapid Burner: 2 x 1,65 KW  
Auxiliary Burner: 1 x 1,10 KW  
Product Dimensions:  
50 x 52 cm



## KO-420 F

### Main Features

Metal Body  
Gas Safety System  
Auto Ignition

### Technical Features

Rapid Burner: 1 x 2,20 KW  
Semi Rapid Burner: 2 x 1,65 KW  
Auxiliary Burner: 1 x 1,10 KW  
Product Dimensions:  
50 x 58 cm



## KO-102

### Main Features

Metal Body  
2 Gas Burner

### Technical Features

Rapid Burner: 1 x 2,20 KW  
Semi Rapid Burner: 1 x 1,65 KW  
Product Dimensions:  
32,5 x 60,5 cm  
Painted or Enameled Options



## KO-123

### Main Features

Metal Body  
3 Gas Burner

### Technical Features

Rapid Burner: 1 x 2,20 KW  
Semi Rapid Burner: 1 x 1,65 KW  
Auxiliary Burner: 1 x 1,10 KW  
Product Dimensions:  
32,5 x 60,5 cm  
Painted or Enameled Options



## KO-104

### Main Features

Metal Body  
4 Gas Burner

### Technical Features

Rapid Burner: 1 x 2,20 KW  
Semi Rapid Burner: 2 x 1,65 KW  
Auxiliary Burner: 1 x 1,10 KW  
Product Dimensions:  
50 x 52 cm  
Painted or Enameled Options



## LX-7011

### Main Features

Hotplate: 1500 W  
Thermosat control  
On-off indicator light

### Technical Features

Product Dimensions:  
26 x 28 cm



## LX-7115

### Main Features

Hotplate: 1500 W  
Thermosat control  
On-off indicator light

### Technical Features

Product Dimensions  
26 x 28 cm



## LX-7021

### Main Features

Big Hotplate: 1500 W  
Small Hotplate: 1000 W  
Thermosat control  
On-off indicator light

### Technical Features

Total Power: 2500 W  
Product Dimensions:  
28 x 50 cm

# COUNTERTOP HOBS

## FEATURES



Model	C3-10 TF	C3-20 BF	C6-40 F	KO-420 F	KO-102	KO-123
Product Type	Counter Top	Counter Top	Counter Top	Counter Top	Counter Top	Counter Top
Location of Control Panel	Front	Front	Side	Side	Front	Front
Hobs Width (Cm)	30	30	60	60	30	30
Flame Failure Device (FFD)	Yes	Yes	Yes	Yes	-	-
Voltage (v)	220-240	220-240	220-240	220-240	-	-
Frequency (Hz)	50-60	50-60	50-60	50-60	-	-
Ignition	Auto	Auto	Auto	Auto	-	-
Pan Support Type	Cast iron - Enamelled	Cast iron - Enamelled	Cast iron - Enamelled	Cast iron - Enamelled	Painted - Enamelled	Painted - Enamelled
Gas Type	LPG or NG (Pool)	LPG or NG (Pool)	LPG or NG (Pool)	LPG or NG (Pipe)	LPG or NG (Pipe)	LPG or NG (Pipe)
Cooking Level	-	-	-	-	-	-
Hob Burner Configuration	1 Tribble	2 Gas	4 Gas	4 Gas	2 Gas	3 Gas
Depth (Mm)	520	520	520	500	605	605
Width (Mm)	290	290	600	580	325	325
Height (Mm)	110	110	110	100	105	105
Weight (Kg)	5,5	5,5	10	7	4	4



Model	KO-104	204 PUNTO	V3-02 P	LX-7115	LX-7011	LX-7021
Product Type	Counter Top	Counter Top	Counter Top	Counter Top	Counter Top	Counter Top
Location of Control Panel	Front	Front	Front	Front	Front	Front
Hobs Width (Cm)	60	60	30	-	-	-
Flame Failure Device (FFD)	-	-	-	-	-	-
Voltage (v)	-	220-240	220-240	220-240	220-240	220-240
Frequency (Hz)	50-60	50-60	50-60	50-60	50-60	50-60
Ignition	-	-	-	-	-	-
Pan Support Type	Painted - Enamelled	Painted - Enamelled	-	-	-	-
Gas Type	LPG or NG (Pipe)	LPG or NG (Pipe)	-	-	-	-
Cooking Level	-	-	9	-	-	-
Hob Burner Configuration	4 Gas	4 Gas	2 Vitroceramic	1 Electric	1 Electric	2 Electric
Depth (Mm)	520	520	520	280	280	500
Width (Mm)	500	500	290	260	260	280
Height (Mm)	110	130	90	80	80	95
Weight (Kg)	6	6	4,5	2,5	2,5	4





# Range Hoods





# RANGE HOODS

---



Remote  
Controller

---

Dishwasher Safe  
Aluminium Filters

---



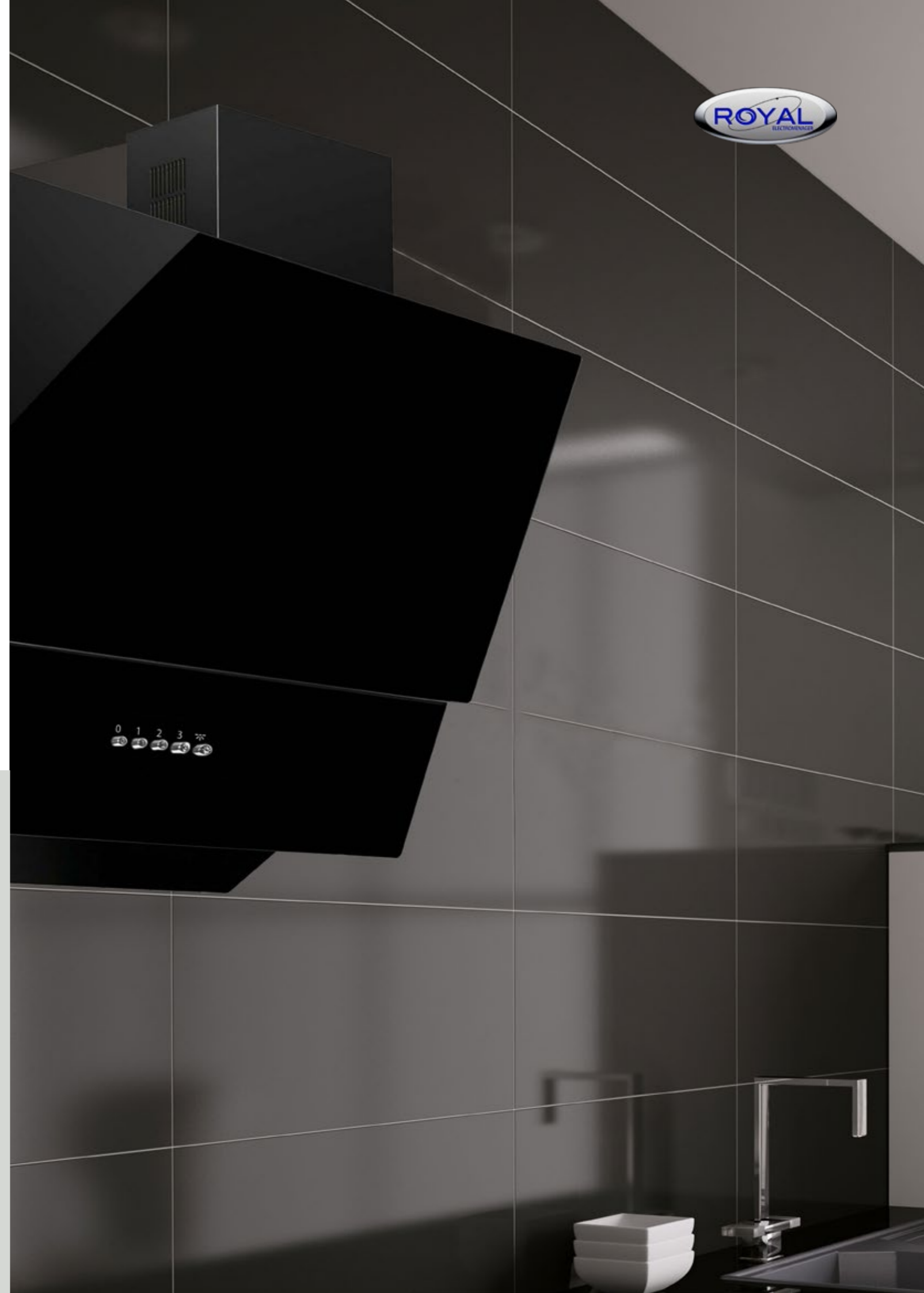

## Carbon Filters

# RANGE HOODS

## FEATURES



**DK6-731**

**Main Features**

Intensive ventilation capacity:  
300 m3/h  
3 Power Level  
Button Control  
Led Lighting  
Dishwasher Safe Filters  
(It has double engine option)  
Color Options:  
Black, White, Grey, Stainless Steel

**Technical Features**  
600 x 480 x 150 mm



**DK6-734**

**Main Features**

Intensive ventilation capacity:  
300 m3/h  
3 Power Level  
Rocker Switch Control  
Led Lighting  
Dishwasher Safe Filters  
(It has double engine option)  
Color Options:  
Black, White, Grey, Stainless Steel

**Technical Features**  
600 x 480 x 150 mm



**DK6-732**

**Main Features**

Intensive ventilation capacity:  
300 m3/h  
3 Power Level  
Knob Control  
Led Lighting  
Dishwasher Safe Filters  
(It has double engine option)  
Color Options:  
Black, White, Grey, Stainless Steel

**Technical Features**  
600 x 480 x 150 mm



**DK6-735**

**Main Features**

Intensive ventilation capacity:  
300 m3/h  
3 Power Level  
Slider Button  
Led Lighting  
Dishwasher Safe Filters (It has  
double engine option)  
Color Options:  
Black, White, Grey, Stainless Steel

**Technical Features**  
600 x 480 x 150 mm



**DK6-733**

**Main Features**

Intensive ventilation capacity:  
300 m3/h  
3 Power Level  
Double Knob Control  
Led Lighting  
Dishwasher Safe Filters  
(It has double engine option)  
Color Options:  
Black, White, Grey, Stainless Steel

**Technical Features**  
600 x 480 x 150 mm



**DK6-736**

**Main Features**

Intensive ventilation capacity:  
300 m3/h  
3 Power Level  
Touch Pad Control  
Led Lighting  
Dishwasher Safe Filters (It has  
double engine option)  
Color Options:  
Black, White, Grey, Stainless Steel

**Technical Features**  
600 x 480 x 150 mm



**DS6-905 A**

**Main Features**

Intensive ventilation capacity:  
300 m3/h  
2 Power Stage  
Rocker Switch Control  
Led Lighting  
Dishwasher Safe Filters  
Color Options:  
Black, White, Grey, Stainless Steel

**Technical Features**  
600 x 495 x 170 mm



**DS6-905 B**

**Main Features**

Intensive ventilation capacity:  
450 m3/h  
3 Power Stage  
Rocker Switch Control  
Led Lighting  
Dishwasher Safe Filters  
Color Options:  
Black, White, Grey, Stainless Steel

**Technical Features**  
600 x 495 x 170 mm



**DP6**

**Main Features**

Intensive ventilation capacity:  
450 m3/h  
3 Power Level  
Button Control  
Led Lighting  
Dishwasher Safe Filters  
Color Options:  
Black, White, Stainless Steel

**Technical Features**  
600 x 450 x 200 mm



**DP6-RB**

**Main Features**

Intensive ventilation capacity:  
450 m3/h  
3 Power Level  
Button Control  
Led Lighting  
Dishwasher Safe Filters  
Color Options:  
Black, Beige

**Technical Features**  
600 x 450 x 200 mm



# RANGE HOODS SPECIFICATION



Model	DK6-905 (Only Engine)	DK6-905 (Double Engine)	DK6-732 (Only Engine)	DK6-732 (Double Engine)	DK6-733 (Only Engine)	DK6-733 (Double Engine)
Product Type	Built-in Hood(Classic)	Built-in Hood(Classic)	Built-in Hood(Classic)	Built-in Hood(Classic)	Built-in Hood(Classic)	Built-in Hood(Classic)
Voltage (v)	220-240	220-240	220-240	220-240	220-240	220-240
Frequency (Hz)	50	50	50	50	50	50
Intensive Ventilation Capacity	300 m <sup>3</sup> /h	450 m <sup>3</sup> /h	300 m <sup>3</sup> /h	450 m <sup>3</sup> /h	300 m <sup>3</sup> /h	450 m <sup>3</sup> /h
Glass	Optional	Optional	Optional	Optional	Optional	Optional
Sound Power dB (A)	66	69	66	69	69	69
Hood Width (Cm)	60	60	60	60	60	60
Control Type	Button	Button	Knob	Knob	Double Knob	Double Knob
Number of Power Levels	3	3	3	3	3	3
Type of Lighting	LED	LED	LED	LED	LED	LED
Remote Controller for Hood	-	-	-	-	-	-
Motor Power	140W	2x90W	140W	2x90W	140W	2x90W
Filter Material	Aluminium	Aluminium	Aluminium	Aluminium	Aluminium	Aluminium
Depth (Mm)	480	480	480	480	480	480
Width (Mm)	600 or 900	600 or 900	600 or 900	600 or 900	600 or 900	600 or 900
Height (Mm)	150	150	150	150	150	150

Color Options: Black, White, Grey, Stainless Steel  
If the 900 mm options is selected, the product name will start with DK9.



Model	DK6-734 (Only Engine)	DK6-734 (Double Engine)	DK6-735 (Only Engine)	DK6-735 (Double Engine)	DK6-736 (Only Engine)	DK6-736 (Double Engine)
Product Type	Built-in Hood(Classic)	Built-in Hood(Classic)	Built-in Hood(Classic)	Built-in Hood(Classic)	Built-in Hood(Classic)	Built-in Hood(Classic)
Voltage (v)	220-240	220-240	220-240	220-240	220-240	220-240
Frequency (Hz)	50	50	50	50	50	50
Intensive Ventilation Capacity	300 m <sup>3</sup> /h	450 m <sup>3</sup> /h	300 m <sup>3</sup> /h	450 m <sup>3</sup> /h	300 m <sup>3</sup> /h	450 m <sup>3</sup> /h
Glass	Optional	Optional	Optional	Optional	Optional	Optional
Sound Power dB (A)	66	69	66	69	66	69
Hood Width (Cm)	60	60	60	60	60	60
Control Type	Rocker Switch	Rocker Switch	Slider Button	Slider Button	Touch Pad	Touch Pad
Number of Power Levels	3	3	3	3	3	3
Type of Lighting	LED	LED	LED	LED	LED	LED
Remote Controller for Hood	-	-	-	-	-	-
Motor Power	140W	2x90W	140W	2x90W	140W	2x90W
Filter Material	Aluminium	Aluminium	Aluminium	Aluminium	Aluminium	Aluminium
Depth (Mm)	480	480	480	480	480	480
Width (Mm)	600 or 900	600 or 900	600 or 900	600 or 900	600 or 900	600 or 900
Height (Mm)	150	150	150	150	150	150

Color Options: Black, White, Grey, Stainless Steel  
If the 900 mm options is selected, the product name will start with DK9.



Model	DS6-905 A	DS6-905 B	DP6	DP6-RS
Product Type	Built-in Hood(Sliding)	Built-in Hood(Sliding)	Built-in Hood(Pyramide)	Built-in Hood(Pyramide)
Voltage (V)	220-240	220-240	220-240	220-240
Frequency (Hz)	50	50	50	50
Glass Q'ty	-	-	-	-
Sound Power dB (A)	67	69	69	69
Hood Width (Cm)	60	60	60	60
Control Type	Button	Button	Button	Button
Number of Power Levels	2	3	3	3
Type of Lighting	Led	Led	Led	Led
Remote Controller for Hood	-	-	-	-
Motor Power	90 W	140 W	140 W	140 W
Filter Material	Aluminium	Aluminium	Aluminium	Aluminium
Depth (Mm)	495	495	450	450
Width (Mm)	600	600	600	600
Height (Mm)	170	170	200	200

Color Options: Black, Beige, Grey, Stainless Steel





# RANGE HOODS FEATURES



**DA6-830**

**Main Features**

Intensive ventilation capacity: 650 m3/h  
2 Glasses  
3 Power Level  
Knob Control  
Led Lighting  
Dishwasher Safe Filters

**Technical Features**

600 x 460 x 365 mm



**DA6-832**

**Main Features**

Intensive ventilation capacity: 650 m3/h  
2 Glasses  
3 Power Level  
Button Control  
Led Lighting  
Dishwasher Safe Filters

**Technical Features**

600 x 460 x 365 mm



**DA6-833**

**Main Features**

Intensive ventilation capacity: 250 m3/h  
1 Glass  
1 Power Level  
Rocker Switch Control  
Led Lighting  
Dishwasher Safe Filters

**Technical Features**

570 x 400 x 365 mm



**DA6-855**

**Main Features**

Intensive ventilation capacity: 650 m3/h  
3 Glasses  
3 Power Level  
Touch Control  
Remote controller for Hood  
Led Lighting  
Dishwasher Safe Filters

**Technical Features**

600 x 480 x 360 mm



**DA6-865**

**Main Features**

Intensive ventilation capacity: 650 m3/h  
3 Glasses  
3 Power Level  
Touch Control  
Remote controller for Hood  
Led Lighting  
Dishwasher Safe Filters

**Technical Features**

600 x 510 x 360 mm



**DA6-875  
(PLATINUM)**

**Main Features**

Intensive ventilation capacity: 800 m3/h  
3 Glasses  
5 Power Level  
Touch Control  
Remote controller for Hood  
Led Lighting  
Dishwasher Safe Filters

**Technical Features**

600 x 510 x 265 mm



**DA6-835**

**Main Features**

Intensive ventilation capacity: 650 m3/h  
2 Glasses  
3 Power Level  
Touch Control  
Remote controller for Hood  
Led Lighting  
Dishwasher Safe Filters

**Technical Features**

600 x 460 x 365 mm





# DA6-875

## PLATINIUM RANGE HOODS



### DA6-875



Motor Type	5 Levels Motor
Flow (Suction Power)	800 m3/h
With / Without Chimney Use	Appropriate
Control Type	Touch Dig. + Remote Cont.
Color Options	White / Black
Aluminum Filter	Washable 5 Layers Aluminium Filter
Noise Level	61 dB
Diameter of Chimney	120 mm
Width	60 cm
Motor Power	212 W
Lighting	Led Lamp
Packing	Box + Seperator



# RANGE HOODS SPECIFICATION



Model	DA6-830	DA6-832	DA6-833	DA6-835	DA6-855	DA6-865	DA6-875
Product Type	Built-in Hood	Built-in Hood	Built-in Hood	Built-in Hood	Built-in Hood	Built-in Hood	Built-in Hood
Voltage (v)	220-240	220-240	220-240	220-240	220-240	220-240	220-240
Frequency (Hz)	50	50	50	50	50	50	50
Glass Q'ty	2	2	1	2	3	3	3
Sound Power dB (A)	63	63	63	63	63	63	61
Hood Width (Cm)	60	60	60	60	60	60	60
Control Type	Knob	Button	Rocker Switch	Touch	Touch	Touch	Touch
Number of Power Levels	3	3	1	3	3	3	3
Type of Lighting	Led	Led	Led	Led	Led	Led	Led
Remote Controller for Hood	-	-	-	Yes	Yes	Yes	Yes
Motor Power	140 W	140 W	100 W	140 W	140 W	140 W	212 W
Filter Material	Aluminium	Aluminium	Aluminium	Aluminium	Aluminium	Aluminium	Aluminium
Depth (Mm)	460	460	400	460	480	510	510
Width (Mm)	600	600	570	600	600	600	600
Height (Mm)	365	365	365	365	365	260	260

Color Options: Black, White, Stone Coal



Model	DA9-830	DA9-832	DA9-833	DA9-835	DA9-855	DA9-865	DA9-875
Product Type	Built-in Hood	Built-in Hood	Built-in Hood	Built-in Hood	Built-in Hood	Built-in Hood	Built-in Hood
Voltage (v)	220-240	220-240	220-240	220-240	220-240	220-240	220-240
Frequency (Hz)	50	50	50	50	50	50	50
Glass Q'ty	2	2	1	2	3	3	3
Sound Power dB (A)	63	63	63	63	63	63	61
Hood Width (Cm)	60	60	60	60	60	60	60
Control Type	Knob	Button	Rocker Switch	Touch	Touch	Touch	Touch
Number of Power Levels	3	3	1	3	3	3	3
Type of Lighting	Led	Led	Led	Led	Led	Led	Led
Remote Controller for Hood	-	-	-	Yes	Yes	Yes	Yes
Motor Power	140 W	140 W	100 W	140 W	140 W	140 W	212 W
Filter Material	Aluminium	Aluminium	Aluminium	Aluminium	Aluminium	Aluminium	Aluminium
Depth (Mm)	460	460	400	460	480	510	510
Width (Mm)	900	900	870	900	900	900	900
Height (Mm)	365	365	365	365	365	260	260

Color Options: Black, White, Stone Coal



Model	DA7-830	DA7-832	DA7-833	DA7-835	DA7-855	DA7-865	DA7-875
Product Type	Built-in Hood	Built-in Hood	Built-in Hood	Built-in Hood	Built-in Hood	Built-in Hood	Built-in Hood
Voltage (v)	220-240	220-240	220-240	220-240	220-240	220-240	220-240
Frequency (Hz)	50	50	50	50	50	50	50
Glass Q'ty	2	2	1	2	3	3	3
Sound Power dB (A)	63	63	63	63	63	63	61
Hood Width (Cm)	60	60	60	60	60	60	60
Control Type	Knob	Button	Rocker Switch	Touch	Touch	Touch	Touch
Number of Power Levels	3	3	1	3	3	3	3
Type of Lighting	Led	Led	Led	Led	Led	Led	Led
Remote Controller for Hood	-	-	-	Yes	Yes	Yes	Yes
Motor Power	140 W	140 W	100 W	140 W	140 W	140 W	212 W
Filter Material	Aluminium	Aluminium	Aluminium	Aluminium	Aluminium	Aluminium	Aluminium
Depth (Mm)	460	460	400	460	480	510	510
Width (Mm)	700	700	670	700	700	700	700
Height (Mm)	365	365	365	365	365	260	260

Color Options: Black, White, Stone Coal





# Technical Details



# BUILT-IN OVENS



## KNOB AND HANDLE OPTIONS

ASYA **KNOB**



DOME **KNOB**



CRYSTAL **KNOB**



PLATINIUM **KNOB**

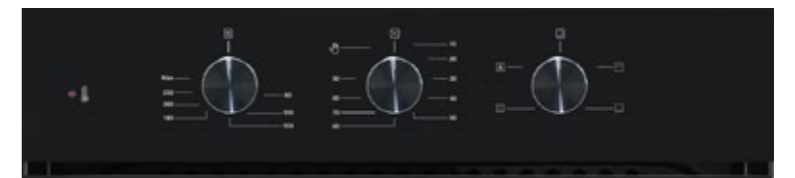

POP-UP **KNOB**



RUSTIK **KNOB**



# PROGRAM OPTIONS

15+1

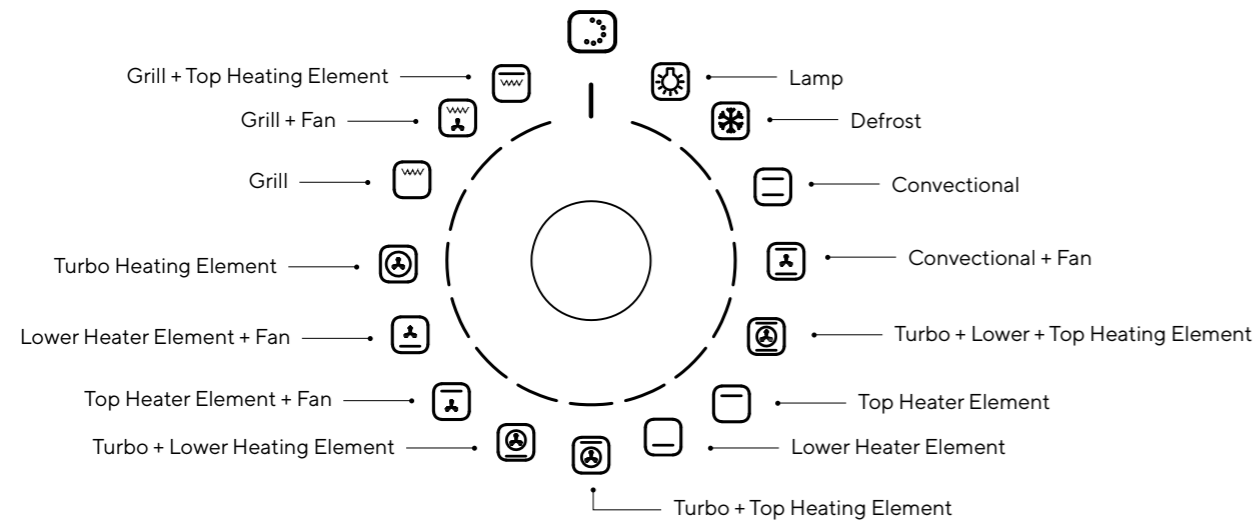

3+1

4+1

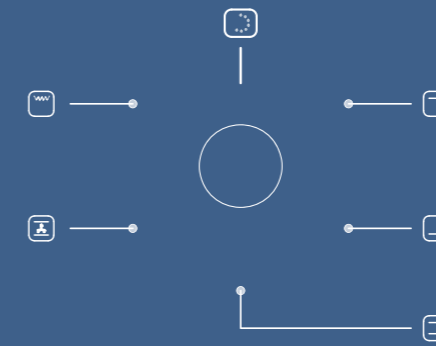
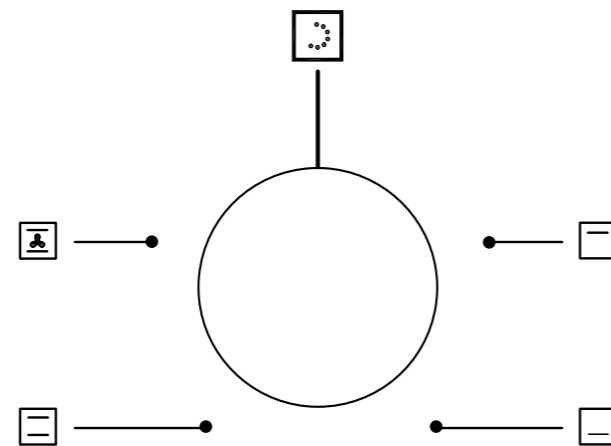
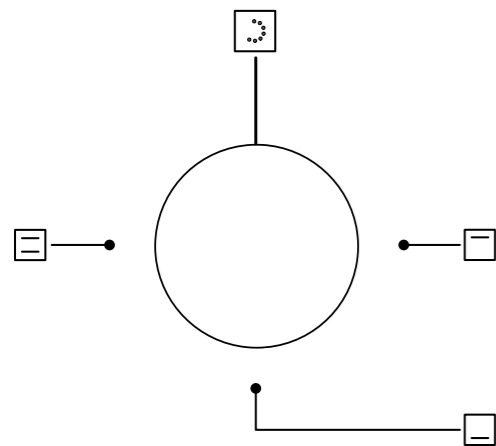

5+1

6+1

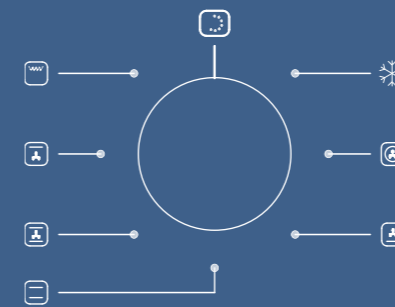
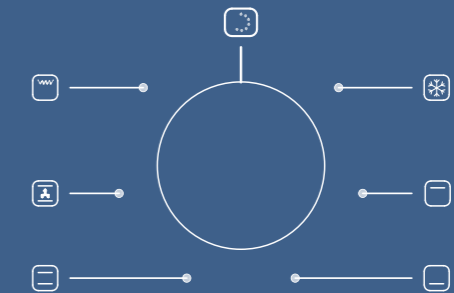

7+1

8+1

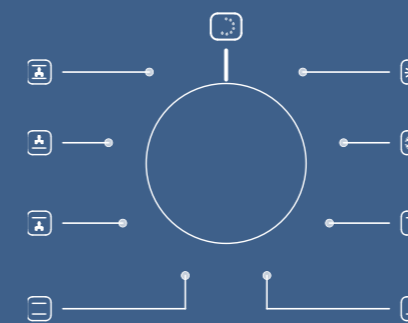
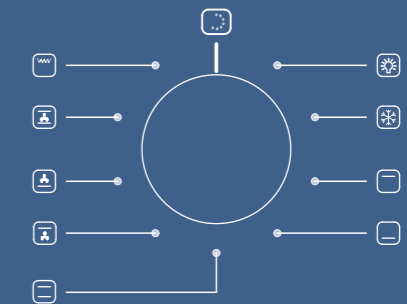

9+1

# KNOB AND HANDLE **OPTIONS**



BABIL **HANDLE**

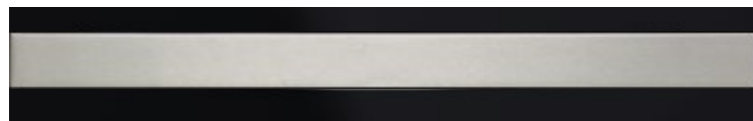

DOLU **HANDLE**



CLASSIC **HANDLE**

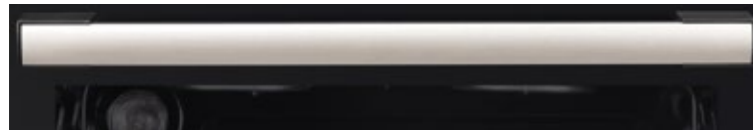

LARA **HANDLE**



MASTER **HANDLE**



RUSTIK **HANDLE**

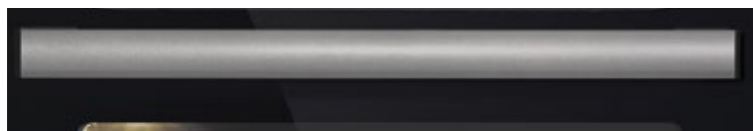

SARAY **HANDLE**





# A6 SERIES

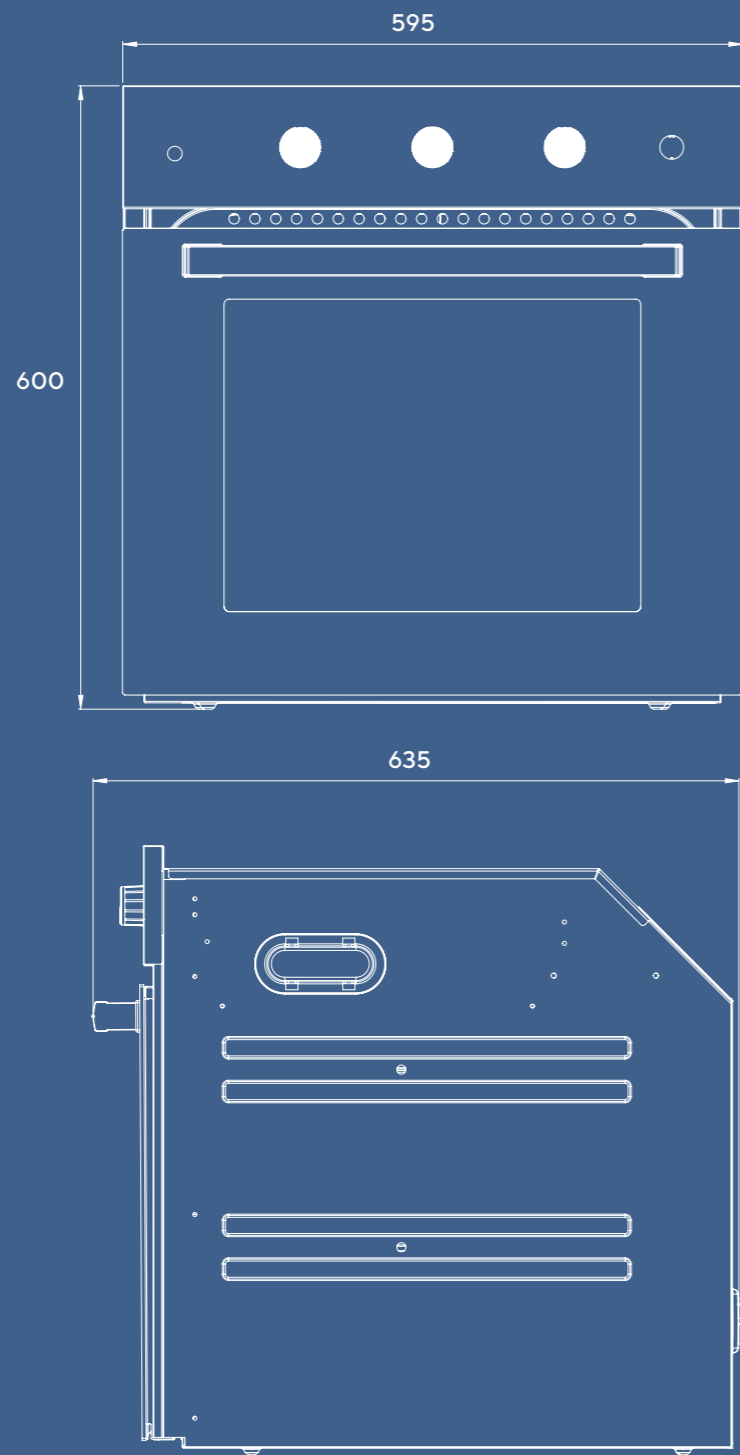

# B66 SERIES

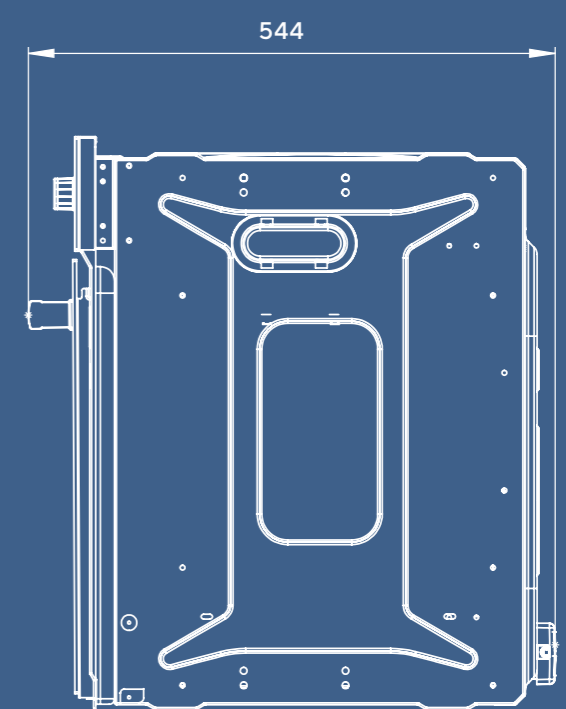
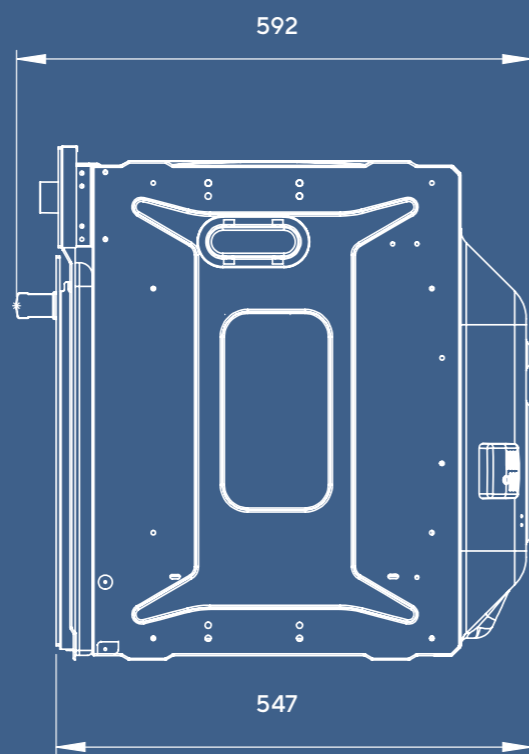
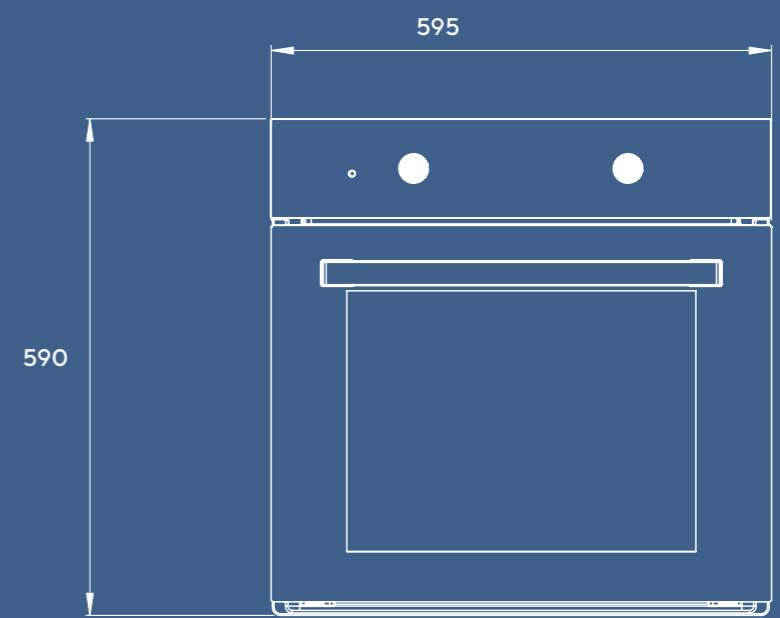
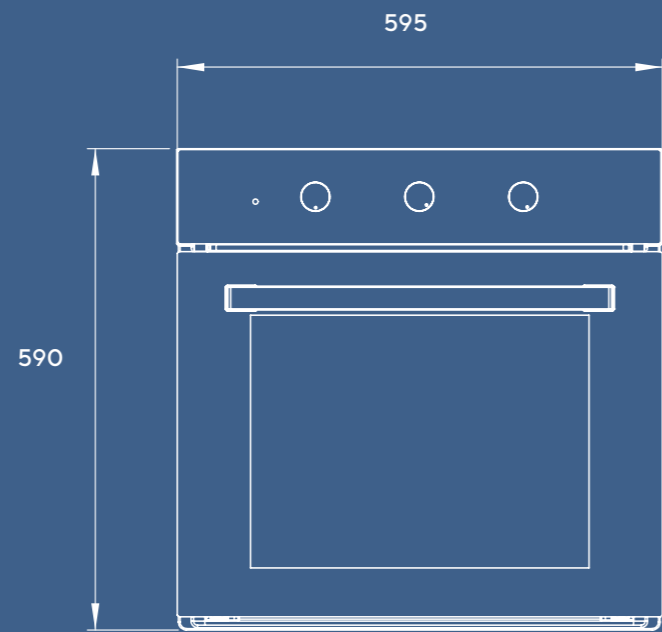



ROYAL

# BUILT-IN COOKER



## KNOB AND HANDLE OPTIONS



**DOME  
KNOB**



**İNCİ  
KNOB**



**CRYSTAL  
KNOB**



**ESİN  
KNOB**



**PLATINIUM  
KNOB**

102  
**WITH LID**

---

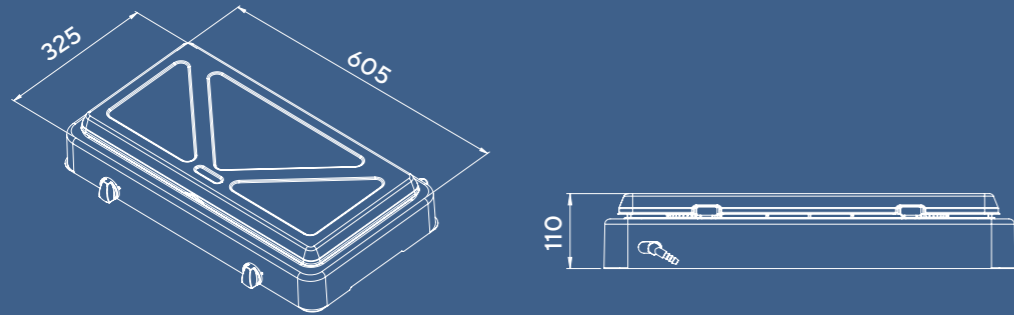

123  
**WITHOUT LID**

---



102  
**WITHOUT LID**

---

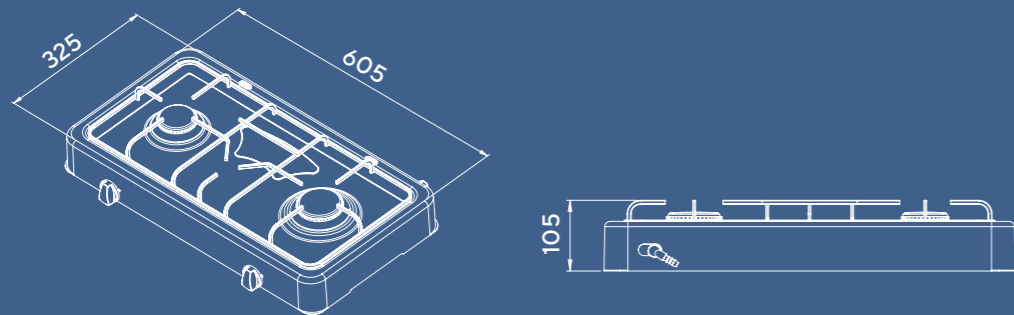

**204**

---

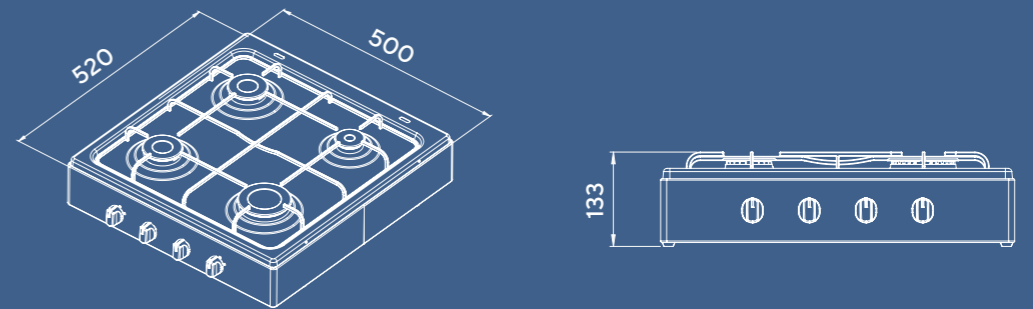

123  
**WITH LID**

---

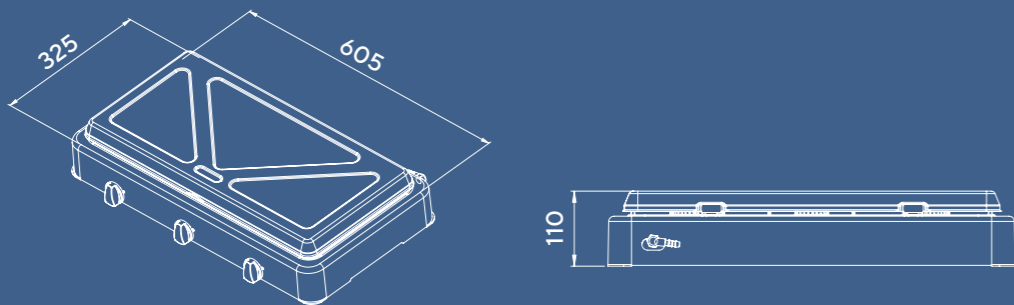

**420**

---

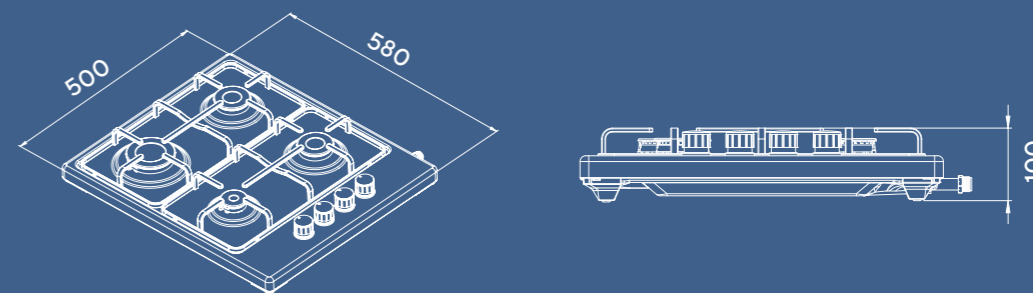

### C3-10WF

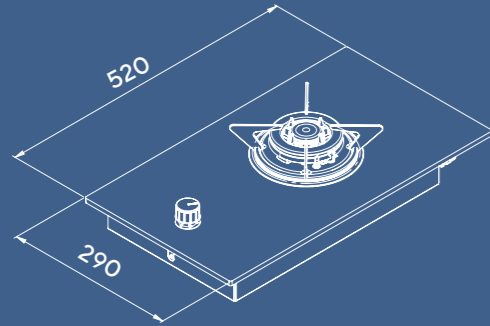

### LX-40TAHDF

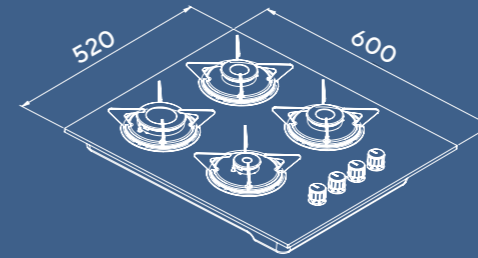

### C3-20F

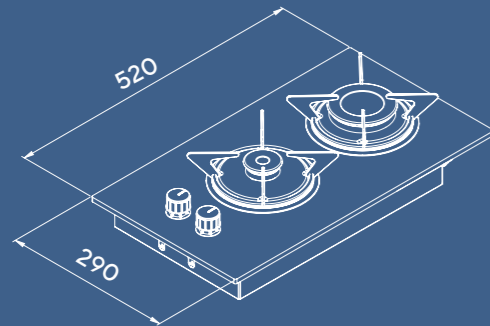

### LX-50OAHDF

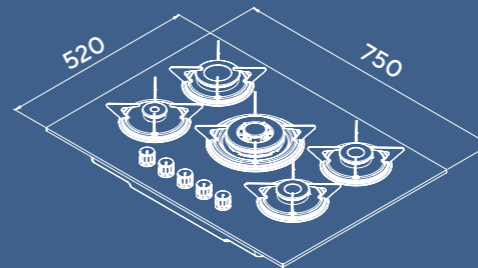

### C9-50WF

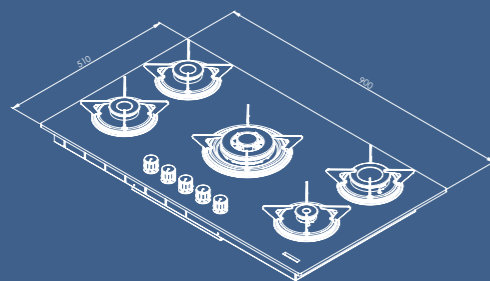

### M6-NIL

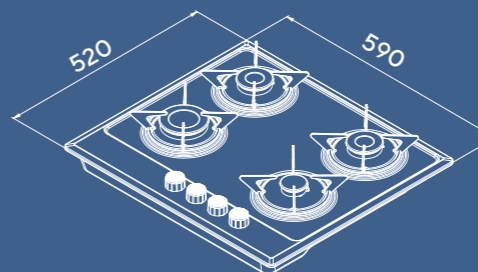

## M6-VIOLET

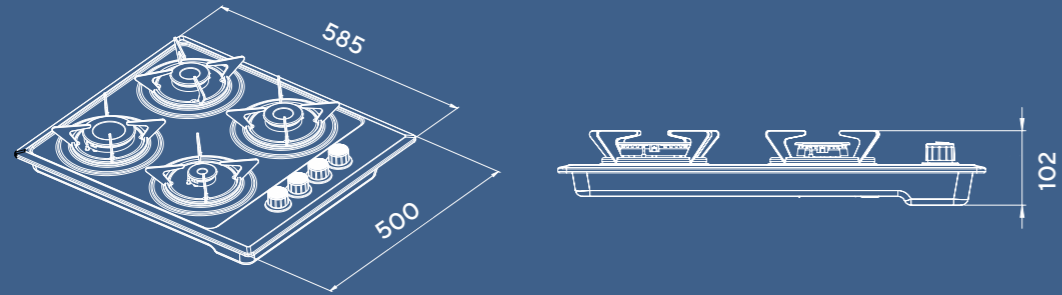

## V6-04T

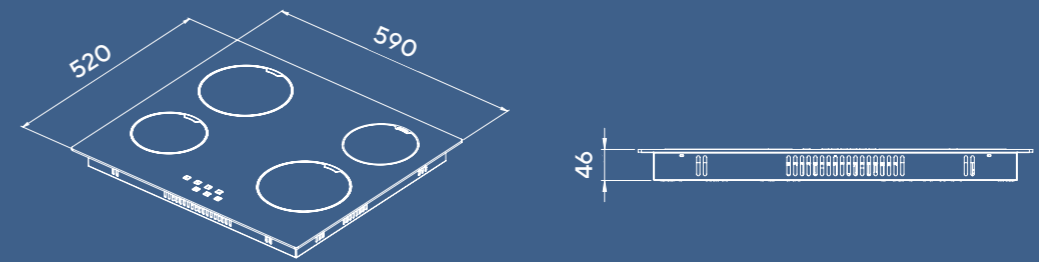

## M7-FLAT

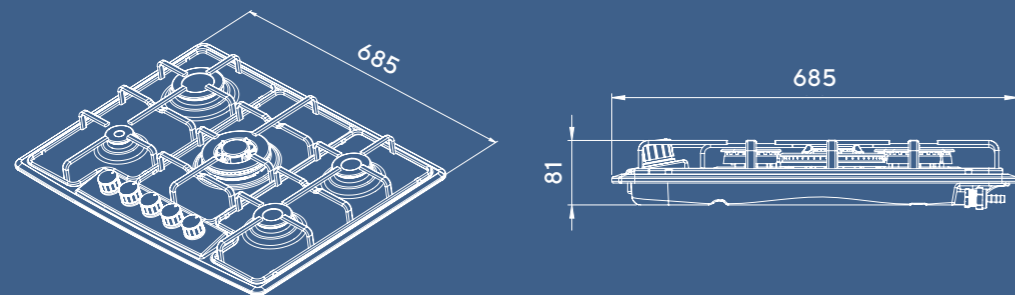

## V6-22PYF

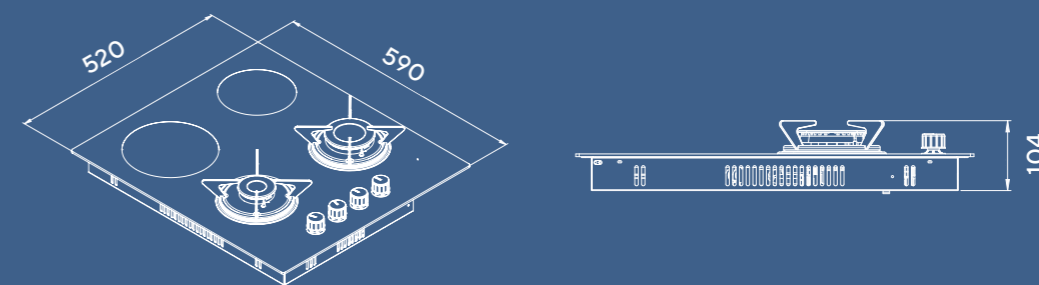

## V3-02P

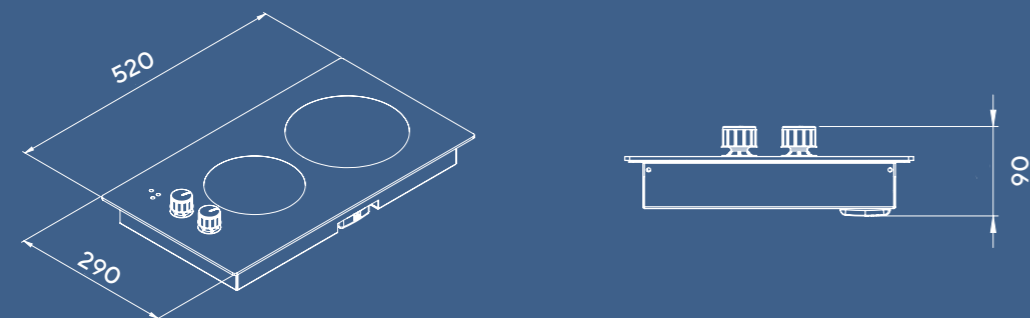



# RANGE HOODS



**DA9-835 MODEL**  
(90 CM)

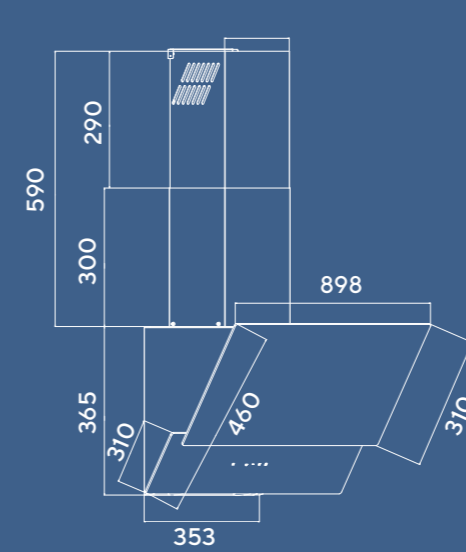

**DA7-835 MODEL**  
(70 CM)

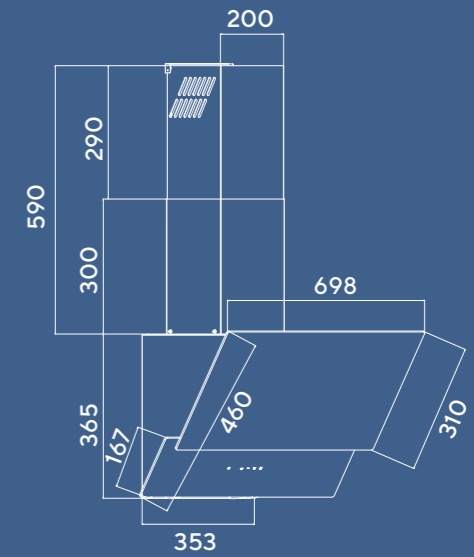

**DA6-855 MODEL**

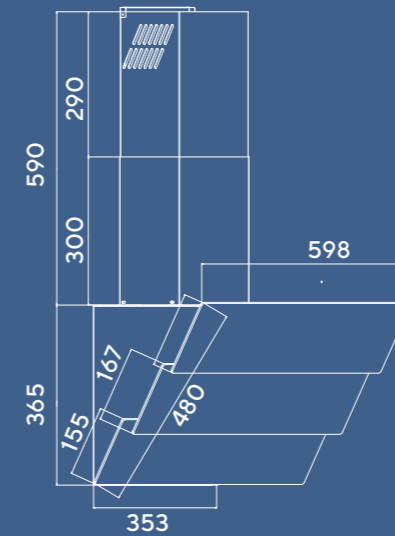

**DA6-835 MODEL**

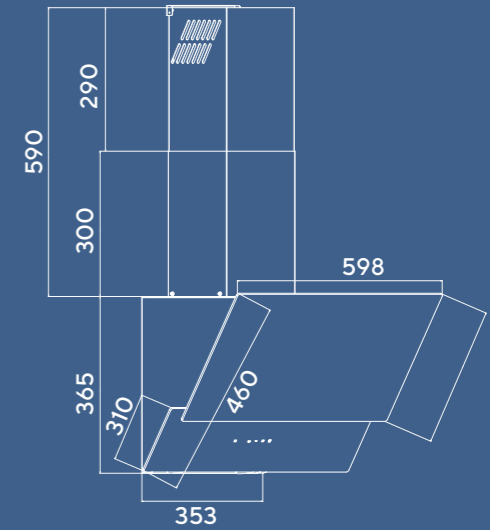

DA6-865 **MODEL**

---

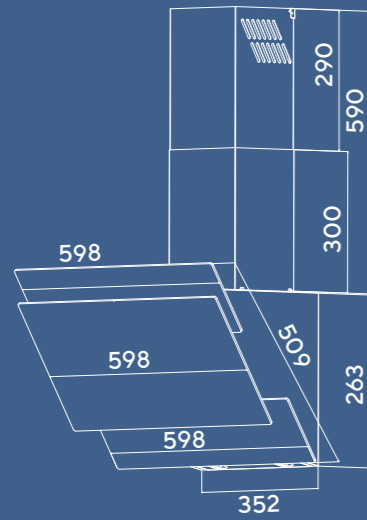

DA6-830

---

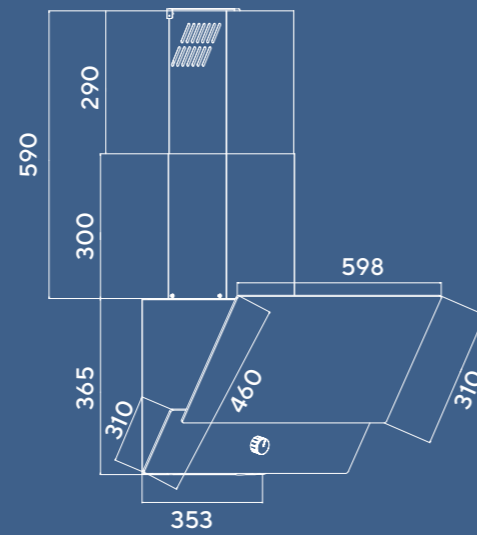

DS6- 905

---

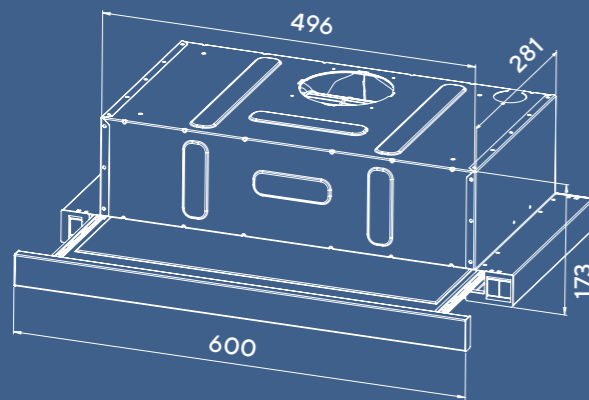

DA6-833

---

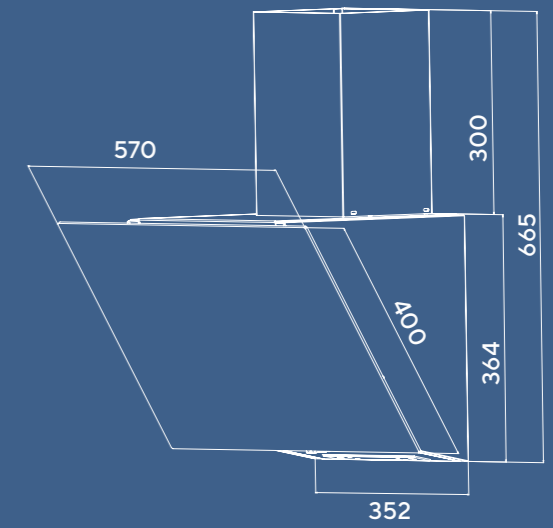

DP6

---

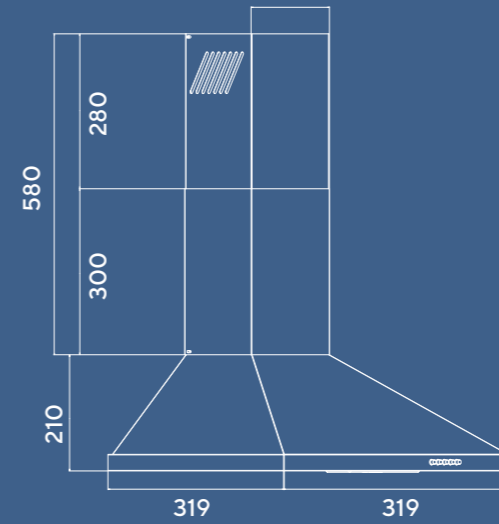

CLASSIC

---

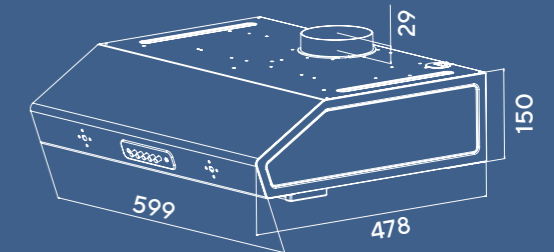





Loading Quantity



# BUILT-IN OVEN



Model	Packing Type	40'HC Loading Quantity
A6	Polyfoam + Shrink	216
B66 S	Polyfoam + Shrink	288
B66 SF	Polyfoam + Shrink	228



# BUILT-IN HOB



Model	Packing Type	40' HC Loading Quantity
V3-02P	Polyfoam + Box	2600
V6-04 T	Polyfoam + Box	1800
V6-22 PYF	Polyfoam + Shrink	1300
V6-31 PYF	Polyfoam + Shrink	1300
C3-10WF	Polyfoam + Shrink	2600
C3-20BF	Polyfoam + Shrink	2600
C6-40 BF	Polyfoam + Shrink	1070
C6-40 WBF	Polyfoam + Shrink	1070
C6-40 BTF (Platinum)	Polyfoam + Shrink	1070
C6-40 TF	Polyfoam + Shrink	1070
C7-50 WF	Polyfoam + Box	880
C9-50 WF	Polyfoam + Box	1000
C9-50 WTF	Polyfoam + Box	1000
KO-410 BF	Polyfoam + Shrink	1300
KO-410 BF	Polyfoam + Box	1600
KO-412 BF	Polyfoam + Shrink	1300
KO-412 BF	Polyfoam + Box	1600
M6-40 BF Violet	Polyfoam + Box	1600
M6-31 BF Violet	Polyfoam + Box	1600
M6-22 BF Violet	Polyfoam + Box	1600
M6-04	Polyfoam + Box	1600
KO-410 BF EKOL	Polyfoam + Box	1650
M6-40 BF Nil	Polyfoam + Box	1300
M6-31 BF Nil	Polyfoam + Box	1300
M6-22 BF Nil	Polyfoam + Box	1300
M6-04 Nil	Polyfoam + Box	1300
M7-50 BF Flat	Polyfoam + Box	1000



# COUNTERTOP HOB



Model	Packing Type	40' HC Loading Quantity
C3-10 WF	Polyfoam + Shrink	2600
C3-20 F	Polyfoam + Shrink	2600
C6-40 F	Polyfoam + Shrink	1070
KO-420 F	Polyfoam + Shrink	1300
KO-420 F	Polyfoam + Box	1600
KO-102	Box	3000
KO-123	Box	3000
KO-104	Box	2250
KO-204	Box	1150
V3-02 P	Polyfoam + Box	2600
LX-7115	Box	7300
LX-7021	Box	4200



# RANGE HOOD



Model	Packing Type	40' HC Loading Quantity
DA6-830	Polyfoam + Box	600
DA6-855	Polyfoam + Box	600
DA6-865	Polyfoam + Box	600
DA6-832	Polyfoam + Box	600
DA6-833	Polyfoam + Box	600
DA6-835	Polyfoam + Box	600
DP-6	Polyfoam + Box	950
DP-6 RB	Polyfoam + Box	950
DA7-830	Polyfoam + Box	550
DA9-830	Polyfoam + Box	400
DK6-905	Polyfoam + Box	2000
DS6-905	Polyfoam + Box	2000



